

# VKDIC - DUAL BLOCK® 2-WAY BALL VALVE

DUAL BLOCK® 2-way ball valve with female ends for solvent welding, metric series

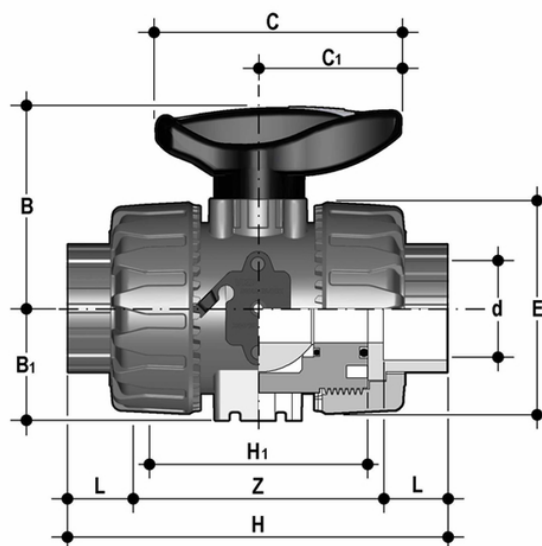

## EPDM

Objednací číslo	Materiál	Kategorie	Série	d	DN	PN	B	B (5:1)	C	C (5:1)	E	H	H (5:1)	L	Z	g
VKDIA016E	ABS systém	Armatury	VKD DN 10÷50	16	10	16	54	29	67	40	54	103	65	14	75	234
VKDIA020E	ABS systém	Armatury	VKD DN 10÷50	20	15	16	54	29	67	40	54	103	65	16	71	223
VKDIA025E	ABS systém	Armatury	VKD DN 10÷50	25	20	16	65	34,5	85	49	65	115	70	19	77	358
VKDIA032E	ABS systém	Armatury	VKD DN 10÷50	32	25	16	69,5	39	85	49	73	128	78	22	84	476
VKDIA040E	ABS systém	Armatury	VKD DN 10÷50	40	32	16	82,5	46	108	64	86	146	88	26	94	753
VKDIA050E	ABS systém	Armatury	VKD DN 10÷50	50	40	16	89	52	108	64	98	164	93	31	102	1007
VKDIA063E	ABS systém	Armatury	VKD DN 10÷50	63	50	16	108	62	134	76	122	199	111	38	123	1717

## FKM

Objednací číslo	Materiál	Kategorie	Série	d	DN	PN	B	B (5:1)	C	C (5:1)	E	H	H (5:1)	L	Z	g
VKDIA016F	ABS systém	Armatury	VKD DN 10÷50	16	10	16	54	29	67	40	54	103	65	14	75	234
VKDIA020F	ABS systém	Armatury	VKD DN 10÷50	20	15	16	54	29	67	40	54	103	65	16	71	223
VKDIA025F	ABS systém	Armatury	VKD DN 10÷50	25	20	16	65	34,5	85	49	65	115	70	19	77	358
VKDIA032F	ABS systém	Armatury	VKD DN 10÷50	32	25	16	69,5	39	85	49	73	128	78	22	84	476
VKDIA040F	ABS systém	Armatury	VKD DN 10÷50	40	32	16	82,5	46	108	64	86	146	88	26	94	753
VKDIA050F	ABS systém	Armatury	VKD DN 10÷50	50	40	16	89	52	108	64	98	164	93	31	102	1007
VKDIA063F	ABS systém	Armatury	VKD DN 10÷50	63	50	16	108	62	134	76	122	199	111	38	123	1717

# VKDIC - DUAL BLOCK® 2-WAY BALL VALVE

- Ergonomic HIPVC handle equipped with **removable tool to adjust the ball seat carrier**.
- **Handle lock 0°- 90°** SHKD (available as an accessory) ergonomically operable during service and padlockable
- Robust **integrated bracket for valve anchoring**, for easy and quick automation even after valve installation on the system via the Power Quick module (optional)
- **DUAL BLOCK®** patented lock system that ensures union nut tightening hold even in severe conditions such as vibrations or heat dilation
- Machined high surface finish ball that guarantees a smooth operation and increased reliability
  
- Connection system for solvent weld, threaded and flanged joints
- Patented **SEAT STOP®** ball carrier system that lets you micro-adjust ball seats and minimise the axial force effect
- Easy radial dismounting allowing quick replacement of O-rings and ball seats without any need for tools
- **PN16 True Union valve body** made for rigid PVC-U injection moulding equipped with built-in bores for actuation. ISO 9393 compliant test requisites
- Option of dismounting downstream pipes with the valve in the closed position
- Floating **full bore ball** with high surface finish
- **Integrated bracket** for valve anchoring
- Ball seat carriers can be adjusted using the **Easytorque adjustment kit**
- Possibility to have handle with integrated LSQT limit micro switch, even as a retrofit in existing installations