

# QHV/Y

Self centering gasket in EPDM and FKM for stubs and flanges according to DIN 2501 and DIN 8063

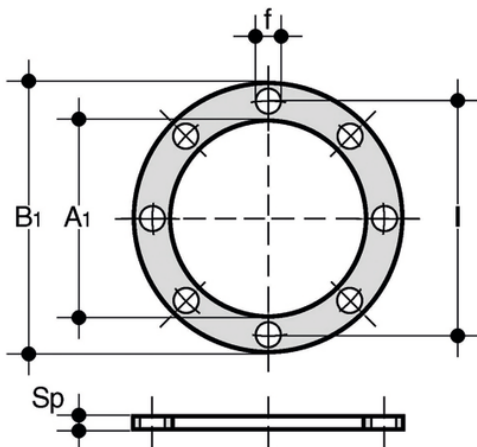

Objednací číslo	d	DN	product.detail.attribute.A[5:1]	B (5:1)	product.detail.attribute.F	product.detail.attribute.l	product.detail.attribute
QHVV020E	20 - 1/2"	15	17	95	14	65	4
QHVV025E	25 - 3/4"	20	22	107	14	76,3	4
QHVV032E	32 - 1"	25	28	117	14	86,5	4
QHVV040E	40 - 1 1/4"	32	36	142,5	18	101	4
QHVV050E	50 - 1 1/2"	40	45	153,3	18	111	4
QHVV063E	63 - 2 1/4"	50	57	168	18	125,5	4
QHVV075E	75 - 2 1/2"	65	71	187,5	18	145,5	4
QHVV090E	90 - 3 3/4"	80	84	203	18	160	8
QHVV110E	110 - 4 1/4"	100	102	223	18	181	8