

SRIM - Ball check valve

Ball check valve with ends for socket welding, metric series

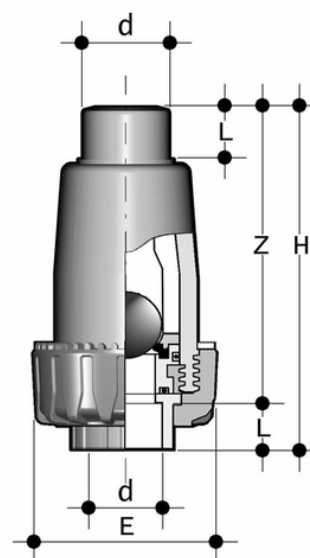

Objednací číslo	Materiál	Kategorie	Série	d	DN	PN	E	H	L	Z	g
SRIM020FOSF	PP-H system	Armatury	SR DN 15+50	20	15	10	55	105	16	89	75
SRIM025FOSF	PP-H system	Armatury	SR DN 15+50	25	20	10	66	126	19	107	140
SRIM032FOSF	PP-H system	Armatury	SR DN 15+50	32	25	10	74	148	22	126	215
SRIM040FOSF	PP-H system	Armatury	SR DN 15+50	40	32	10	86	172	26	146	320
SRIM050FOSF	PP-H system	Armatury	SR DN 15+50	50	40	10	99	189	31	158	440
SRIM063FOSF	PP-H system	Armatury	SR DN 15+50	63	50	10	120	224	38	186	750

SRIM – Ball check valve

- Ergonomic HIPVC handle equipped with **removable tool to adjust the ball seat carrier**.
- **Handle lock 0°– 90°** SHKD (available as an accessory) ergonomically operable during service and padlockable
- Robust **integrated bracket for valve anchoring**, for easy and quick automation even after valve installation on the system via the Power Quick module (optional)
- **DUAL BLOCK®** patented lock system that ensures union nut tightening hold even in severe conditions such as vibrations or heat dilation

- Connection system for weld joints
- PN10 **valve body made for PP-H injection moulding** and European Directive 2014/68/EU (PED) compliant for pressurised equipment. ISO 9393 compliant test requirements
- The valve can only be used with fluids with specific weight under 1,20 g/cm³
- **Sealing system with antiblow out design**
- Ball entirely in talc-filled PP
- Can be maintained with the valve body installed
- Can be **installed** in either a **vertical** (preferable) or **horizontal position**