

VKDIM/SHX – DUAL BLOCK® 2-way ball valve

Dual Block® 2-way ball valve with handle lock and STAINLESS steel threaded inserts with female ends for socket welding, metric series

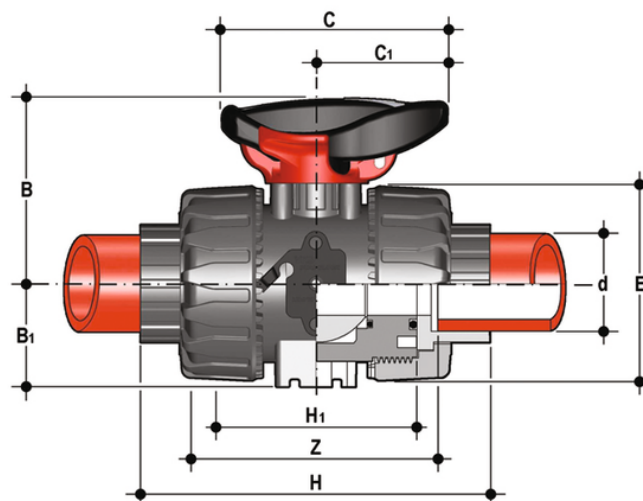

EPDM

Objednací číslo	Materiál	Kategorie	Série	d	DN	PN	B	B (5:1)	C	C (5:1)	E	H	H (5:1)	Z	g
VKDIMSHX016E	PP-H system	Armatury	VKD DN 10÷50	16	10	10	54	29	67	40	54	102	65	74,5	160
VKDIMSHX020E	PP-H system	Armatury	VKD DN 10÷50	20	15	10	54	29	67	40	54	102	65	73	155
VKDIMSHX025E	PP-H system	Armatury	VKD DN 10÷50	25	20	10	65	34,5	85	49	65	114	70	82	228
VKDIMSHX032E	PP-H system	Armatury	VKD DN 10÷50	32	25	10	69,5	39	85	49	73	126	78	90	308
VKDIMSHX040E	PP-H system	Armatury	VKD DN 10÷50	40	32	10	82,5	46	108	64	86	141	88	100	490
VKDIMSHX050E	PP-H system	Armatury	VKD DN 10÷50	50	40	10	89	52	108	64	98	164	93	117	692
VKDIMSHX063E	PP-H system	Armatury	VKD DN 10÷50	63	50	10	108	62	134	76	122	199	111	144	1176

FKM

Objednací číslo	Materiál	Kategorie	Série	d	DN	PN	B	B (5:1)	C	C (5:1)	E	H	H (5:1)	Z	g
VKDIMSHX016F	PP-H system	Armatury	VKD DN 10÷50	16	10	10	54	29	67	40	54	102	65	74,5	160
VKDIMSHX020F	PP-H system	Armatury	VKD DN 10÷50	20	15	10	54	29	67	40	54	102	65	73	155
VKDIMSHX025F	PP-H system	Armatury	VKD DN 10÷50	25	20	10	65	34,5	85	49	65	114	70	82	228
VKDIMSHX032F	PP-H system	Armatury	VKD DN 10÷50	32	25	10	69,5	39	85	49	73	126	78	90	308
VKDIMSHX040F	PP-H system	Armatury	VKD DN 10÷50	40	32	10	82,5	46	108	64	86	141	88	100	490
VKDIMSHX050F	PP-H system	Armatury	VKD DN 10÷50	50	40	10	89	52	108	64	98	164	93	117	692
VKDIMSHX063F	PP-H system	Armatury	VKD DN 10÷50	63	50	10	108	62	134	76	122	199	111	144	1176

VKDIM/SHX – DUAL BLOCK® 2-way ball valve

- Ergonomic HIPVC handle equipped with **removable tool to adjust the ball seat carrier**.
- **Handle lock 0°– 90°** SHKD (available as an accessory) ergonomically operable during service and padlockable
- Robust **integrated bracket for valve anchoring**, for easy and quick automation even after valve installation on the system via the Power Quick module (optional)
- **DUAL BLOCK®** patented lock system that ensures union nut tightening hold even in severe conditions such as vibrations or heat dilation
- Machined high surface finish ball that guarantees a smooth operation and increased reliability

- Connection system for solvent weld, threaded and flanged joints
- Patented **SEAT STOP®** ball carrier system that lets you micro-adjust ball seats and minimise the axial force effect
- Easy radial dismounting allowing quick replacement of O-rings and ball seats without any need for tools
- **PN16 True Union valve body** made for rigid PVC-U injection moulding equipped with built-in bores for actuation. ISO 9393 compliant test requisites
- Option of dismounting downstream pipes with the valve in the closed position
- Floating **full bore ball** with high surface finish
- **Integrated bracket** for valve anchoring
- Ball seat carriers can be adjusted using the **Easytorque adjustment kit**
- Possibility to have handle with integrated LSQT limit micro switch, even as a retrofit in existing installations