

VKDBF - DUAL BLOCK® 2-way ball valve

DUAL BLOCK® 2-way ball valve with long spigot male ends in PVDF for butt welding/ IR (CVDF)

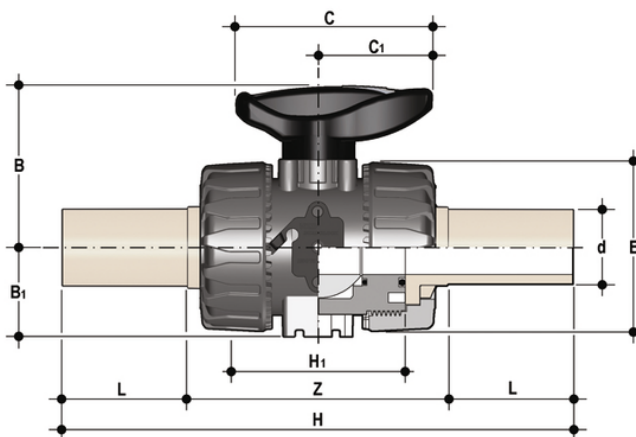

VKDBF - DUAL BLOCK® 2-way ball valve

Objednačí číslo	Materiál	Kategorie	Série
VKDBF020F	PVDF system	Armatury	VKD DN 10÷50
VKDBF025F	PVDF system	Armatury	VKD DN 10÷50
VKDBF032F	PVDF system	Armatury	VKD DN 10÷50
VKDBF040F	PVDF system	Armatury	VKD DN 10÷50
VKDBF050F	PVDF system	Armatury	VKD DN 10÷50
VKDBF063F	PVDF system	Armatury	VKD DN 10÷50

VKDBF - DUAL BLOCK® 2-way ball valve

Objednačí číslo	Materiál	Kategorie	Série
VKDBF020FOLF	PVDF system	Armatury	VKD DN 10÷50
VKDBF025FOLF	PVDF system	Armatury	VKD DN 10÷50
VKDBF032FOLF	PVDF system	Armatury	VKD DN 10÷50
VKDBF040FOLF	PVDF system	Armatury	VKD DN 10÷50
VKDBF050FOLF	PVDF system	Armatury	VKD DN 10÷50
VKDBF063FOLF	PVDF system	Armatury	VKD DN 10÷50

VKDBF - DUAL BLOCK® 2-way ball valve

VKDBF – DUAL BLOCK® 2-way ball valve

Objednací číslo	Materiál	Kategorie	Série
VKDBF020FOSF	PVDF system	Armatury	VKD DN 10÷50
VKDBF025FOSF	PVDF system	Armatury	VKD DN 10÷50
VKDBF032FOSF	PVDF system	Armatury	VKD DN 10÷50
VKDBF040FOSF	PVDF system	Armatury	VKD DN 10÷50
VKDBF050FOSF	PVDF system	Armatury	VKD DN 10÷50
VKDBF063FOSF	PVDF system	Armatury	VKD DN 10÷50

VKDBF – DUAL BLOCK® 2-way ball valve

- Ergonomic HIPVC handle equipped with **removable tool to adjust the ball seat carrier**.
- **Handle lock 0°– 90°** SHKD (available as an accessory) ergonomically operable during service and padlockable
- Robust **integrated bracket for valve anchoring**, for easy and quick automation even after valve installation on the system via the Power Quick module (optional)
- **DUAL BLOCK®** patented lock system that ensures union nut tightening hold even in severe conditions such as vibrations or heat dilation
- Machined high surface finish ball that guarantees a smooth operation and increased reliability

- Connection system for solvent weld, threaded and flanged joints
- Patented **SEAT STOP®** ball carrier system that lets you micro-adjust ball seats and minimise the axial force effect
- Easy radial dismounting allowing quick replacement of O-rings and ball seats without any need for tools
- **PN16 True Union valve body** made for rigid PVC-U injection moulding equipped with built-in bores for actuation. ISO 9393 compliant test requisites
- Option of dismounting downstream pipes with the valve in the closed position
- Floating **full bore ball** with high surface finish
- **Integrated bracket** for valve anchoring
- Ball seat carriers can be adjusted using the **Easytorque adjustment kit**
- Possibility to have handle with integrated LSQT limit micro switch, even as a retrofit in existing installations