

LKDDM - DUAL BLOCK® 3-way ball valve

DUAL BLOCK® 3-way ball valve with male ends for socket welding, metric series, L-port ball.

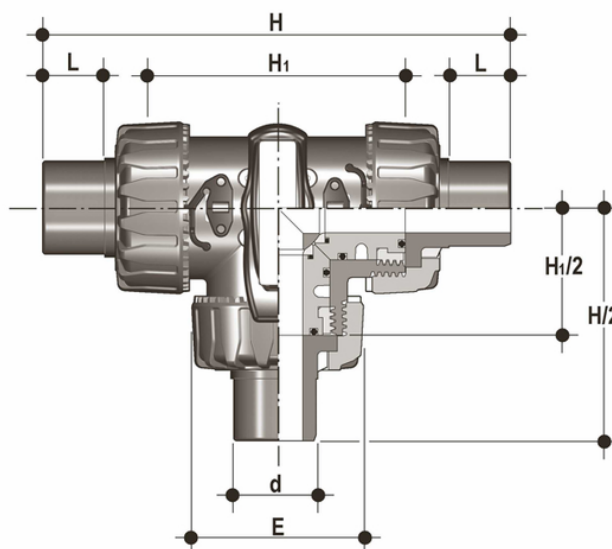

EPDM

Objednací číslo	Materiál	Kategorie	Série	d	DN	PN	E	H	H (5:1)	L	g
LKDDM020E	PP-H system	Armatury	TKD DN 10÷50	20	15	10	54	140	80	16	205
LKDDM025E	PP-H system	Armatury	TKD DN 10÷50	25	20	10	65	175	100	18	360
LKDDM032E	PP-H system	Armatury	TKD DN 10÷50	32	25	10	73	188	110	20	515
LKDDM040E	PP-H system	Armatury	TKD DN 10÷50	40	32	10	86	220	131	22	835
LKDDM050E	PP-H system	Armatury	TKD DN 10÷50	50	40	10	98	251	148	23	1100
LKDDM063E	PP-H system	Armatury	TKD DN 10÷50	63	50	10	122	294	179	29	1830

FKM

Objednací číslo	Materiál	Kategorie	Série	d	DN	PN	E	H	H (5:1)	L	g
LKDDM020F	PP-H system	Armatury	TKD DN 10÷50	20	15	10	54	140	80	16	205
LKDDM025F	PP-H system	Armatury	TKD DN 10÷50	25	20	10	65	175	100	18	360
LKDDM032F	PP-H system	Armatury	TKD DN 10÷50	32	25	10	73	188	110	20	515
LKDDM040F	PP-H system	Armatury	TKD DN 10÷50	40	32	10	86	220	131	22	835
LKDDM050F	PP-H system	Armatury	TKD DN 10÷50	50	40	10	98	251	148	23	1100
LKDDM063F	PP-H system	Armatury	TKD DN 10÷50	63	50	10	122	294	179	29	1830

LKDDM - DUAL BLOCK® 3-way ball valve

- Ergonomic HIPVC handle equipped with removable tool to adjust the ball seat carrier. Possibility of installing the **LTKD stroke limiter** (available as an accessory) that permits ball and handle rotation only for set opening and closing angles at 90° or 180°
- **Handle lock 0°- 90° SHKD** (available as an accessory) ergonomically operable during service and padlockable
- **DUAL BLOCK®** patented lock system that ensures union nut tightening hold even in severe conditions such as vibrations or heat dilation
- **Ball shutter** high surface finish with floating type full passage with **T or L port**
- **4 PTFE ball seat system** that compensates axial force guaranteeing optimal manageability and long working life

- Connection system for weld and threaded joints
- Patented **SEAT STOP®** ball seat carrier system that lets you micro-adjust ball seats and minimise axial force effects
- Easy radial disassembly allowing quick replacement of O-rings and ball seats without any need for tools
- PN10 **True Union valve body** made for PP-H injection moulding equipped with built-in bores for actuation. ISO 9393 compliant test requisites
- Option of disassembling downstream pipes with the valve in the closed position
- High surface finish stem with double O-Ring and double groove ball connection, equipped with **optical position indicator** for correct handle installation
- **Integrated bracket** for valve anchoring
- Possibility of installing pneumatic and/or electric actuators thanks to the robust integrated bracket for valve anchoring for easy and quick automation using the Power Quick module (optional)
- Possibility to have handle with integrated LSQT limit micro switch, even as a retrofit in existing installations