

VKDBEV – DUAL BLOCK® 2-way ball valve

DUAL BLOCK® 2-way ball valve with PE100 SDR 11 male end connectors for butt welding or electrofusion (CVDE)

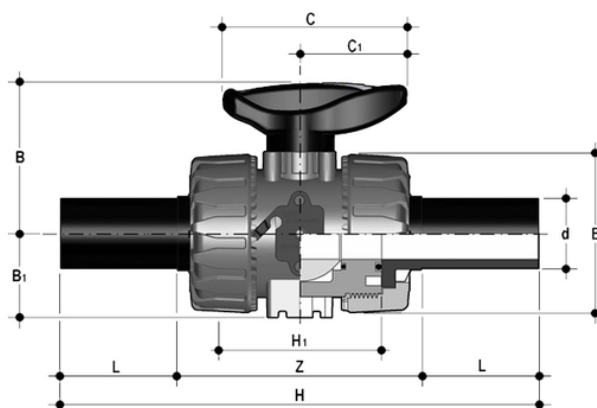

EPDM

Objednací číslo	Materiál	Kategorie	Série	d	DN	PN	B	B (5:1)	C	C (5:1)	E	H	H (5:1)	L	Z	g
VKDBEV020E	PVC-U system	Armatury	VKD DN 10÷50	20	15	16	54	29	67	40	54	175	65	40,5	94	220
VKDBEV025E	PVC-U system	Armatury	VKD DN 10÷50	25	20	16	65	34,5	85	49	65	213	70	54	106	340
VKDBEV032E	PVC-U system	Armatury	VKD DN 10÷50	32	25	16	69,5	39	85	49	73	228	78	56	117	443
VKDBEV040E	PVC-U system	Armatury	VKD DN 10÷50	40	32	16	82,5	46	108	64	86	247	88	56	131	693
VKDBEV050E	PVC-U system	Armatury	VKD DN 10÷50	50	40	16	89	52	108	64	98	271	93	60,5	145	945
VKDBEV063E	PVC-U system	Armatury	VKD DN 10÷50	63	50	16	108	62	134	76	122	300	111	65,5	161	1607

FKM

Objednací číslo	Materiál	Kategorie	Série	d	DN	PN	B	B (5:1)	C	C (5:1)	E	H	H (5:1)	L	Z	g
VKDBEV020F	PVC-U system	Armatury	VKD DN 10÷50	20	15	16	54	29	67	40	54	175	65	40,5	94	220
VKDBEV025F	PVC-U system	Armatury	VKD DN 10÷50	25	20	16	65	34,5	85	49	65	213	70	54	106	340
VKDBEV032F	PVC-U system	Armatury	VKD DN 10÷50	32	25	16	69,5	39	85	49	73	228	78	56	117	443
VKDBEV040F	PVC-U system	Armatury	VKD DN 10÷50	40	32	16	82,5	46	108	64	86	247	88	56	131	693
VKDBEV050F	PVC-U system	Armatury	VKD DN 10÷50	50	40	16	89	52	108	64	98	271	93	60,5	145	945
VKDBEV063F	PVC-U system	Armatury	VKD DN 10÷50	63	50	16	108	62	134	76	122	300	111	65,5	161	1607

VKDBEV – DUAL BLOCK® 2-way ball valve

- Ergonomic HIPVC handle equipped with **removable tool to adjust the ball seat carrier**.
- **Handle lock 0°– 90°** SHKD (available as an accessory) ergonomically operable during service and padlockable
- Robust **integrated bracket for valve anchoring**, for easy and quick automation even after valve installation on the system via the Power Quick module (optional)
- **DUAL BLOCK®** patented lock system that ensures union nut tightening hold even in severe conditions such as vibrations or heat dilation
- Machined high surface finish ball that guarantees a smooth operation and increased reliability

- Connection system for solvent weld, threaded and flanged joints
- Patented **SEAT STOP®** ball carrier system that lets you micro-adjust ball seats and minimise the axial force effect
- Easy radial dismounting allowing quick replacement of O-rings and ball seats without any need for tools
- **PN16 True Union valve body** made for rigid PVC-U injection moulding equipped with built-in bores for actuation. ISO 9393 compliant test requisites
- Option of dismounting downstream pipes with the valve in the closed position
- Floating **full bore ball** with high surface finish
- **Integrated bracket** for valve anchoring
- Ball seat carriers can be adjusted using the **Easytorque adjustment kit**
- Possibility to have handle with integrated LSQT limit micro switch, even as a retrofit in existing installations