

VKDOC - DUAL BLOCK® 2-WAY BALL VALVE

DUAL BLOCK® 2-way ball valve with fixed flanges, drilled EN/ISO/DIN PN10/16. Face to face according to EN 558-1

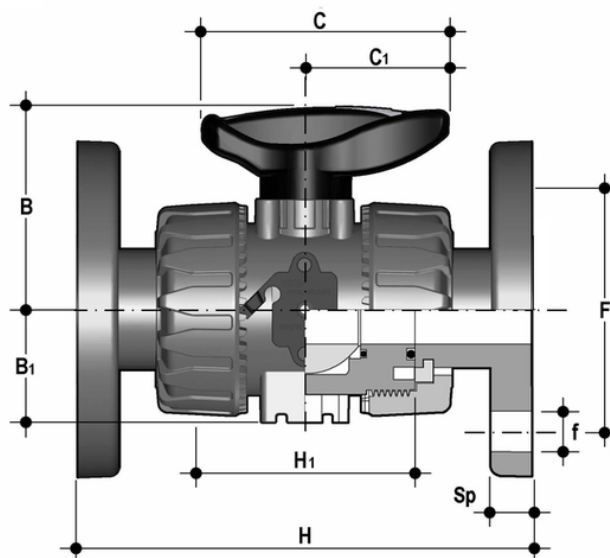

EPDM

Objednáací číslo	Materiál	Kategorie	Série	d	DN	PN	B	B (5:1)	C	C (5:1)	product.detail.attribute.F	product.detail.attribute.f	H	H (5:1)	product
VKDOC020E	PVC-C system	Armatury	VKD DN 10÷50	20	15	16	54	29	67	40	65	14	130	65	11
VKDOC025E	PVC-C system	Armatury	VKD DN 10÷50	25	20	16	65	34,5	85	49	75	14	150	70	13,5
VKDOC032E	PVC-C system	Armatury	VKD DN 10÷50	32	25	16	69,5	39	85	49	85	14	160	78	14
VKDOC040E	PVC-C system	Armatury	VKD DN 10÷50	40	32	16	82,5	46	108	64	100	18	180	88	14
VKDOC050E	PVC-C system	Armatury	VKD DN 10÷50	50	40	16	89	52	108	64	110	18	200	93	16
VKDOC063E	PVC-C system	Armatury	VKD DN 10÷50	63	50	16	108	62	134	76	125	18	230	111	16

FKM

VKDOC - DUAL BLOCK® 2-WAY BALL VALVE

Objednací číslo	Materiál	Kategorie	Série	d	DN	PN	B	B (5:1)	C	C (5:1)	product.detail.attribute.F	product.detail.attribute.f	H	H (5:1)	product
VKDOC020F	PVC-C system	Armatury	VKD DN 10÷50	20	15	16	54	29	67	40	65	14	130	65	11
VKDOC025F	PVC-C system	Armatury	VKD DN 10÷50	25	20	16	65	34,5	85	49	75	14	150	70	13,5
VKDOC032F	PVC-C system	Armatury	VKD DN 10÷50	32	25	16	69,5	39	85	49	85	14	160	78	14
VKDOC040F	PVC-C system	Armatury	VKD DN 10÷50	40	32	16	82,5	46	108	64	100	18	180	88	14
VKDOC050F	PVC-C system	Armatury	VKD DN 10÷50	50	40	16	89	52	108	64	110	18	200	93	16
VKDOC063F	PVC-C system	Armatury	VKD DN 10÷50	63	50	16	108	62	134	76	125	18	230	111	16

VKDOC – DUAL BLOCK® 2-WAY BALL VALVE

- Ergonomic HIPVC handle equipped with **removable tool to adjust the ball seat carrier**.
- **Handle lock 0°– 90°** SHKD (available as an accessory) ergonomically operable during service and padlockable
- Robust **integrated bracket for valve anchoring**, for easy and quick automation even after valve installation on the system via the Power Quick module (optional)
- **DUAL BLOCK®** patented lock system that ensures union nut tightening hold even in severe conditions such as vibrations or heat dilation
- Machined high surface finish ball that guarantees a smooth operation and increased reliability

- Connection system for solvent weld, threaded and flanged joints
- Patented **SEAT STOP®** ball carrier system that lets you micro-adjust ball seats and minimise the axial force effect
- Easy radial dismounting allowing quick replacement of O-rings and ball seats without any need for tools
- **PN16 True Union valve body** made for rigid PVC-U injection moulding equipped with built-in bores for actuation. ISO 9393 compliant test requisites
- Option of dismounting downstream pipes with the valve in the closed position
- Floating **full bore ball** with high surface finish
- **Integrated bracket** for valve anchoring
- Ball seat carriers can be adjusted using the **Easytorque adjustment kit**
- Possibility to have handle with integrated LSQT limit micro switch, even as a retrofit in existing installations