

VKRBEV - DUAL BLOCK® regulating ball valve

Dual Block® regulating ball valve with PE100 SDR 11 male end connectors for butt welding or electrofusion (CVDE)

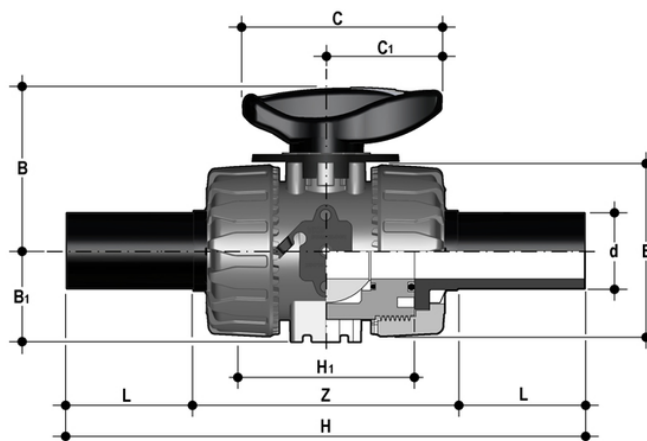

EPDM

Objednací číslo	Materiál	Kategorie	Série	d	DN	PN	B	B (5:1)	C	C (5:1)	E	H	H (5:1)	L	Z	g
VKRBEV020E	PVC-U system	Armatury	VKR DN 10÷50	20	15	16	54	29	67	40	54	175	65	40,5	94	220
VKRBEV025E	PVC-U system	Armatury	VKR DN 10÷50	25	20	16	65	34,5	85	49	65	213	70	54	106	340
VKRBEV032E	PVC-U system	Armatury	VKR DN 10÷50	32	25	16	69,5	39	85	49	73	228	78	56	117	443
VKRBEV040E	PVC-U system	Armatury	VKR DN 10÷50	40	32	16	82,5	46	108	64	86	247	88	56	131	693
VKRBEV050E	PVC-U system	Armatury	VKR DN 10÷50	50	40	16	89	52	108	64	98	271	93	60,5	145	945
VKRBEV063E	PVC-U system	Armatury	VKR DN 10÷50	63	50	16	108	62	134	76	122	300	111	65,5	161	1607

FKM

Objednací číslo	Materiál	Kategorie	Série	d	DN	PN	B	B (5:1)	C	C (5:1)	E	H	H (5:1)	L	Z	g
VKRBEV020F	PVC-U system	Armatury	VKR DN 10÷50	20	15	16	54	29	67	40	54	175	65	40,5	94	220
VKRBEV025F	PVC-U system	Armatury	VKR DN 10÷50	25	20	16	65	34,5	85	49	65	213	70	54	106	340
VKRBEV032F	PVC-U system	Armatury	VKR DN 10÷50	32	25	16	69,5	39	85	49	73	228	78	56	117	443
VKRBEV040F	PVC-U system	Armatury	VKR DN 10÷50	40	32	16	82,5	46	108	64	86	247	88	56	131	693
VKRBEV050F	PVC-U system	Armatury	VKR DN 10÷50	50	40	16	89	52	108	64	98	271	93	60,5	145	945
VKRBEV063F	PVC-U system	Armatury	VKR DN 10÷50	63	50	16	108	62	134	76	122	300	111	65,5	161	1607

VKRBEV – DUAL BLOCK®

regulating ball valve

- HIPVC ergonomic multifunctional handle with **position indicator** and tool to adjust the ball seat carrier
- Flow direction and opening angle indication plate with **graduated scale with 5° detail** for clear and accurate readings
- 90° operating angle that permits **the use of standard** quarter turn **actuators**
- The patented ball design provides **linear flow adjustment** throughout its range of operation even when the valve is open just a few degrees and guarantees minimum pressure drops
- Patented **DUAL BLOCK®** system: prevents union nuts from loosening even under extreme operating conditions: e.g. vibration or thermal expansion

- Connection system for solvent weld, threaded and flanged joints
- Patented **SEAT STOP®** ball carrier system that lets you micro-adjust seals and minimise the axial force effect
- Easy radial dismounting allowing quick replacement of O-rings and ball seats without any need for tools
- **PN16 True Union valve body** made for rigid PVC-U injection moulding equipped with built-in bores for actuation. ISO 9393 compliant test requisites
- Option of dismounting downstream pipes with the valve in the closed position
- High surface finish stem with double O-Ring and double connection key to ball
- **Integrated bracket** for valve anchoring
- Ball seat carrier can be adjusted using the **Easytorque adjustment kit**
- Actuation option: version with electric modulating actuator with 4-20 mA / 0-10 V inlet and 4-20 mA / 0-10 V outlet to monitor the position
- Valve suitable for carrying fluids that are clean and free of suspended particles