

VKDOAC – DUAL BLOCK® 2-WAY BALL VALVE

DUAL BLOCK® 2-way ball valve with fixed flanges, drilled ANSI B16.5 cl.150 #FF

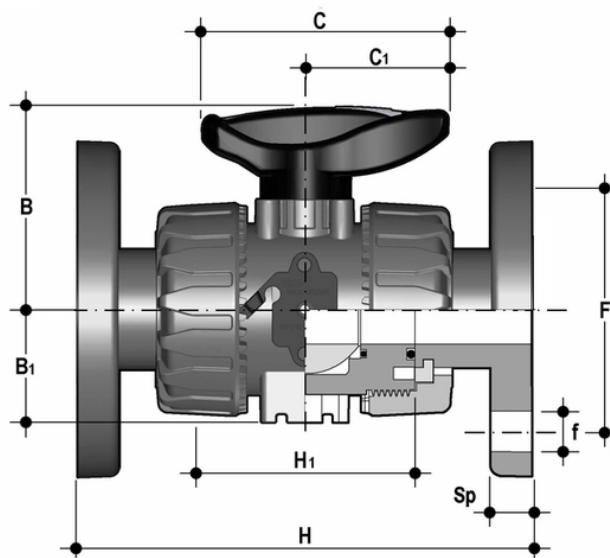

EPDM

Objednáací číslo	Materiál	Kategorie	Série	d	DN	PN	B	B (5:1)	C	C (5:1)	product.detail.attribute.F	product.detail.attribute.f	H	H (5:1)	prod
VKDOAC012E	PVC-C system	Armatury	VKD DN 10÷50	1/2"	15	16	54	29	67	40	60,3	15,9	143	65	11
VKDOAC034E	PVC-C system	Armatury	VKD DN 10÷50	3/4"	20	16	65	34,5	85	49	69,9	15,9	172	70	13,5
VKDOAC100E	PVC-C system	Armatury	VKD DN 10÷50	1"	25	16	69,5	39	85	49	79,4	15,9	187	78	14
VKDOAC114E	PVC-C system	Armatury	VKD DN 10÷50	1" 1/4	32	16	82,5	46	108	64	88,9	15,9	190	88	14
VKDOAC112E	PVC-C system	Armatury	VKD DN 10÷50	1" 1/2	40	16	89	52	108	64	98,4	15,9	212	93	16
VKDOAC200E	PVC-C system	Armatury	VKD DN 10÷50	2"	50	16	108	62	134	76	120,7	19,1	234	111	16

FKM

VKDOAC – DUAL BLOCK® 2-WAY BALL VALVE

Objednací číslo	Materiál	Kategorie	Série	d	DN	PN	B	B (5:1)	C	C (5:1)	product.detail.attribute.F	product.detail.attribute.f	H	H (5:1)	prod
VKDOAC012F	PVC-C system	Armatury	VKD DN 10÷50	1/2"	15	16	54	29	67	40	60,3	15,9	143	65	11
VKDOAC034F	PVC-C system	Armatury	VKD DN 10÷50	3/4"	20	16	65	34,5	85	49	69,9	15,9	172	70	13,5
VKDOAC100F	PVC-C system	Armatury	VKD DN 10÷50	1"	25	16	69,5	39	85	49	79,4	15,9	187	78	14
VKDOAC114F	PVC-C system	Armatury	VKD DN 10÷50	1" 1/4	32	16	82,5	46	108	64	88,9	15,9	190	88	14
VKDOAC112F	PVC-C system	Armatury	VKD DN 10÷50	1" 1/2	40	16	89	52	108	64	98,4	15,9	212	93	16
VKDOAC200F	PVC-C system	Armatury	VKD DN 10÷50	2"	50	16	108	62	134	76	120,7	19,1	234	111	16

VKDOAC – DUAL BLOCK® 2-WAY BALL VALVE

- Ergonomic HIPVC handle equipped with **removable tool to adjust the ball seat carrier**.
- **Handle lock 0°– 90°** SHKD (available as an accessory) ergonomically operable during service and padlockable
- Robust **integrated bracket for valve anchoring**, for easy and quick automation even after valve installation on the system via the Power Quick module (optional)
- **DUAL BLOCK®** patented lock system that ensures union nut tightening hold even in severe conditions such as vibrations or heat dilation
- Machined high surface finish ball that guarantees a smooth operation and increased reliability

- Connection system for solvent weld, threaded and flanged joints
- Patented **SEAT STOP®** ball carrier system that lets you micro-adjust ball seats and minimise the axial force effect
- Easy radial dismounting allowing quick replacement of O-rings and ball seats without any need for tools
- **PN16 True Union valve body** made for rigid PVC-U injection moulding equipped with built-in bores for actuation. ISO 9393 compliant test requisites
- Option of dismounting downstream pipes with the valve in the closed position
- Floating **full bore ball** with high surface finish
- **Integrated bracket** for valve anchoring
- Ball seat carriers can be adjusted using the **Easytorque adjustment kit**
- Possibility to have handle with integrated LSQT limit micro switch, even as a retrofit in existing installations