

VXELV - Easyfit 2-way ball valve

Easyfit 2-way ball valve with female ends for solvent welding, BS series

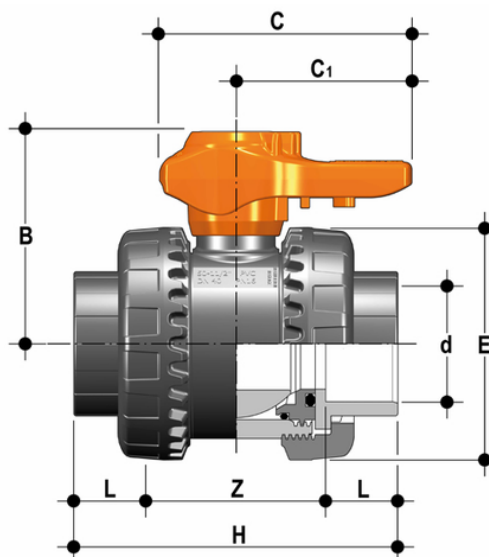

EPDM

Objednací číslo	Materiál	Kategorie	Série	d	DN	PN	B	C	C (5:1)	E	H	L	Z	g
VXELV038E	PVC-U system	Armatury	VXE DN 10÷50	3/8"	10	16	49	64	44	54	78	14,5	49	180
VXELV012E	PVC-U system	Armatury	VXE DN 10÷50	1/2"	15	16	49	64	44	54	82	16,5	49	175
VXELV034E	PVC-U system	Armatury	VXE DN 10÷50	3/4"	20	16	62	78	55	63	91	19	53	260
VXELV100E	PVC-U system	Armatury	VXE DN 10÷50	1"	25	16	71	87	60	72	103	22,5	58	365
VXELV114E	PVC-U system	Armatury	VXE DN 10÷50	1 1/4"	32	16	82	102	72	85	120	26	68	565
VXELV112E	PVC-U system	Armatury	VXE DN 10÷50	1 1/2"	40	16	92	109	76	100	139	30	79	795
VXELV200E	PVC-U system	Armatury	VXE DN 10÷50	2"	50	16	110	133	94	118	174	36	102	1325

FKM

Objednací číslo	Materiál	Kategorie	Série	d	DN	PN	B	C	C (5:1)	E	H	L	Z	g
VXELV038F	PVC-U system	Armatury	VXE DN 10÷50	3/8"	10	16	49	64	44	54	78	14,5	49	180
VXELV012F	PVC-U system	Armatury	VXE DN 10÷50	1/2"	15	16	49	64	44	54	82	16,5	49	175
VXELV034F	PVC-U system	Armatury	VXE DN 10÷50	3/4"	20	16	62	78	55	63	91	19	53	260
VXELV100F	PVC-U system	Armatury	VXE DN 10÷50	1"	25	16	71	87	60	72	103	22,5	58	365
VXELV114F	PVC-U system	Armatury	VXE DN 10÷50	1 1/4"	32	16	82	102	72	85	120	26	68	565
VXELV112F	PVC-U system	Armatury	VXE DN 10÷50	1 1/2"	40	16	92	109	76	100	139	30	79	795
VXELV200F	PVC-U system	Armatury	VXE DN 10÷50	2"	50	16	110	133	94	118	174	36	102	1325

VXELV – Easyfit 2-way ball valve

- Two position **Easyfit ergonomic multifunctional handle with union nut tightening control** which can be used to **adjust ball seat carriers**. Handle use is especially indicated for **maintenance** work where **space is limited** and hard to access
- **Customisable Labelling System: built-in LCE module** on the handle made up of a transparent protection plug and customisable tag holder with LSE set (available as accessory). The customisation potential lets you **identify the valve on the system** according to specific needs
- **The PTFE ball seat system with locked carrier** adjustable via Easyfit multifunctional handle or Easytorque adjustment kit (available as an accessory)
- High surface finish **valve stem with double O-Ring**, produced in CNC work stations to achieve precise dimensional tolerance and increased reliability
- Machined high surface finish ball that guarantees a smooth operation and increased reliability

- **Patented Easyfit system**: innovative mechanism based on the principle of the bevel gear pair that controls valve union nut rotation during installation
- Connection system for solvent weld and threaded joints
- **Valve material compatibility** (PVC-C) and elastomer **seal elements** (EPDM or FKM), with water, drinking water and other food substances as per **current regulations**
- Easy radial disassembly allowing quick replacement of O-rings and ball seats without any need for tools
- **PN16 True Union valve body** made for PVC-C injection moulding and European Directive 2014/68/EU (PED) compliant for pressurised equipment. ISO 9393 compliant test requirements
- Fully interchangeable with previous VX Ergo series models
- Option of disassembling downstream pipes with the valve in the closed position
- Floating **full bore ball** with high surface finish made in CNC work stations to achieve precise dimensional tolerance and high surface finish