

VKDDV - DUAL BLOCK® 2-way ball valve

DUAL BLOCK® 2-way ball valve with male ends for solvent welding, metric series

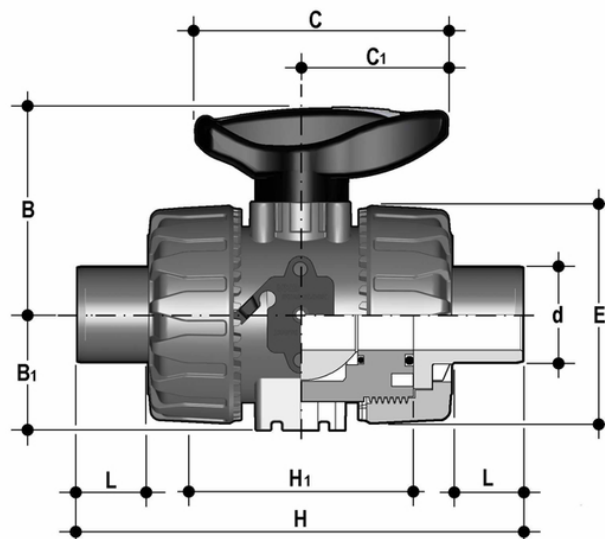

EPDM

Objednací číslo	Materiál	Kategorie	Série	d	DN	PN	B	B (5:1)	C	C (5:1)	E	H	H (5:1)	L	g
VKDDV016E	PVC-U system	Armatury	VKD DN 10÷50	16	10	16	54	29	67	40	54	149	65	14	215
VKDDV020E	PVC-U system	Armatury	VKD DN 10÷50	20	15	16	54	29	67	40	54	124	65	16	220
VKDDV025E	PVC-U system	Armatury	VKD DN 10÷50	25	20	16	65	34,5	85	49	65	144	70	19	340
VKDDV032E	PVC-U system	Armatury	VKD DN 10÷50	32	25	16	69,5	39	85	49	73	154	78	22	443
VKDDV040E	PVC-U system	Armatury	VKD DN 10÷50	40	32	16	82,5	46	108	64	86	174	88	26	693
VKDDV050E	PVC-U system	Armatury	VKD DN 10÷50	50	40	16	89	52	108	64	98	194	93	31	945
VKDDV063E	PVC-U system	Armatury	VKD DN 10÷50	63	50	16	108	62	134	76	122	224	111	38	1607

FKM

Objednací číslo	Materiál	Kategorie	Série	d	DN	PN	B	B (5:1)	C	C (5:1)	E	H	H (5:1)	L	g
VKDDV016F	PVC-U system	Armatury	VKD DN 10÷50	16	10	16	54	29	67	40	54	149	65	14	215
VKDDV020F	PVC-U system	Armatury	VKD DN 10÷50	20	15	16	54	29	67	40	54	124	65	16	220
VKDDV025F	PVC-U system	Armatury	VKD DN 10÷50	25	20	16	65	34,5	85	49	65	144	70	19	340
VKDDV032F	PVC-U system	Armatury	VKD DN 10÷50	32	25	16	69,5	39	85	49	73	154	78	22	443
VKDDV040F	PVC-U system	Armatury	VKD DN 10÷50	40	32	16	82,5	46	108	64	86	174	88	26	693
VKDDV050F	PVC-U system	Armatury	VKD DN 10÷50	50	40	16	89	52	108	64	98	194	93	31	945
VKDDV063F	PVC-U system	Armatury	VKD DN 10÷50	63	50	16	108	62	134	76	122	224	111	38	1607

VKDDV - DUAL BLOCK® 2-way ball valve

- Ergonomic HIPVC handle equipped with **removable tool to adjust the ball seat carrier**.
- **Handle lock 0°- 90°** SHKD (available as an accessory) ergonomically operable during service and padlockable
- Robust **integrated bracket for valve anchoring**, for easy and quick automation even after valve installation on the system via the Power Quick module (optional)
- **DUAL BLOCK®** patented lock system that ensures union nut tightening hold even in severe conditions such as vibrations or heat dilation
- Machined high surface finish ball that guarantees a smooth operation and increased reliability

- Connection system for solvent weld, threaded and flanged joints
- Patented **SEAT STOP®** ball carrier system that lets you micro-adjust ball seats and minimise the axial force effect
- Easy radial dismounting allowing quick replacement of O-rings and ball seats without any need for tools
- **PN16 True Union valve body** made for rigid PVC-U injection moulding equipped with built-in bores for actuation. ISO 9393 compliant test requisites
- Option of dismounting downstream pipes with the valve in the closed position
- Floating **full bore ball** with high surface finish
- **Integrated bracket** for valve anchoring
- Ball seat carriers can be adjusted using the **Easytorque adjustment kit**
- Possibility to have handle with integrated LSQT limit micro switch, even as a retrofit in existing installations