

VKRAV - DUAL BLOCK® regulating ball valve

DUAL BLOCK® regulating ball valve with female ends for solvent welding, ASTM series

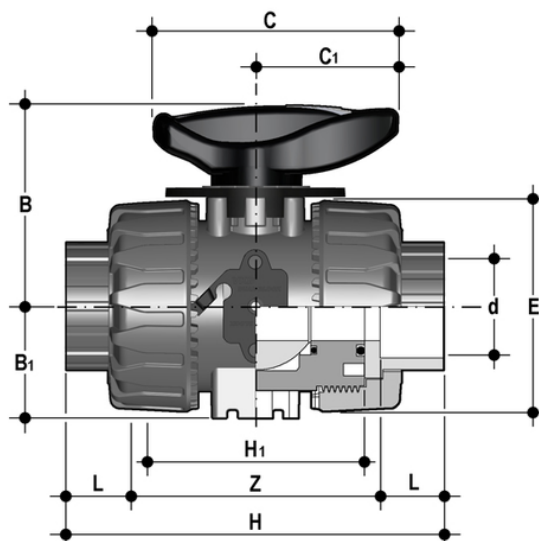

EPDM

Objednací číslo	Materiál	Kategorie	Série	d	DN	PN	B	B (5:1)	C	C (5:1)	E	H	H (5:1)	L	Z	g
VKRAV038E	PVC-U system	Armatury	VKR DN 10÷50	3/8"	10	16	54	29	67	40	54	117	65	19,5	78	230
VKRAV012E	PVC-U system	Armatury	VKR DN 10÷50	1/2"	15	16	54	29	67	40	54	117	65	22,5	72	215
VKRAV034E	PVC-U system	Armatury	VKR DN 10÷50	3/4"	20	16	65	34,5	85	49	65	129	70	25,5	78	345
VKRAV100E	PVC-U system	Armatury	VKR DN 10÷50	1"	25	16	69,5	39	85	49	73	142	78	28,7	84,6	448
VKRAV114E	PVC-U system	Armatury	VKR DN 10÷50	1" 1/4	32	16	82,5	46	108	64	86	162	88	32	98	718
VKRAV112E	PVC-U system	Armatury	VKR DN 10÷50	1" 1/2	40	16	89	52	108	64	98	172	93	35	102	975
VKRAV200E	PVC-U system	Armatury	VKR DN 10÷50	2"	50	16	108	62	134	76	122	199	111	38,2	122,6	1712

FKM

Objednací číslo	Materiál	Kategorie	Série	d	DN	PN	B	B (5:1)	C	C (5:1)	E	H	H (5:1)	L	Z	g
VKRAV038F	PVC-U system	Armatury	VKR DN 10÷50	3/8"	10	16	54	29	67	40	54	117	65	19,5	78	230
VKRAV012F	PVC-U system	Armatury	VKR DN 10÷50	1/2"	15	16	54	29	67	40	54	117	65	22,5	72	215
VKRAV034F	PVC-U system	Armatury	VKR DN 10÷50	3/4"	20	16	65	34,5	85	49	65	129	70	25,5	78	345
VKRAV100F	PVC-U system	Armatury	VKR DN 10÷50	1"	25	16	69,5	39	85	49	73	142	78	28,7	84,6	448
VKRAV114F	PVC-U system	Armatury	VKR DN 10÷50	1" 1/4	32	16	82,5	46	108	64	86	162	88	32	98	718
VKRAV112F	PVC-U system	Armatury	VKR DN 10÷50	1" 1/2	40	16	89	52	108	64	98	172	93	35	102	975
VKRAV200F	PVC-U system	Armatury	VKR DN 10÷50	2"	50	16	108	62	134	76	122	199	111	38,2	122,6	1712

VKRAV – DUAL BLOCK® regulating ball valve

- HIPVC ergonomic multifunctional handle with **position indicator** and tool to adjust the ball seat carrier
- Flow direction and opening angle indication plate with **graduated scale with 5° detail** for clear and accurate readings
- 90° operating angle that permits **the use of standard** quarter turn **actuators**
- The patented ball design provides **linear flow adjustment** throughout its range of operation even when the valve is open just a few degrees and guarantees minimum pressure drops
- Patented **DUAL BLOCK®** system: prevents union nuts from loosening even under extreme operating conditions: e.g. vibration or thermal expansion

- Connection system for solvent weld, threaded and flanged joints
- Patented **SEAT STOP®** ball carrier system that lets you micro-adjust seals and minimise the axial force effect
- Easy radial dismounting allowing quick replacement of O-rings and ball seats without any need for tools
- **PN16 True Union valve body** made for rigid PVC-U injection moulding equipped with built-in bores for actuation. ISO 9393 compliant test requisites
- Option of dismounting downstream pipes with the valve in the closed position
- High surface finish stem with double O-Ring and double connection key to ball
- **Integrated bracket** for valve anchoring
- Ball seat carrier can be adjusted using the **Easytorque adjustment kit**
- Actuation option: version with electric modulating actuator with 4-20 mA / 0-10 V inlet and 4-20 mA / 0-10 V outlet to monitor the position
- Valve suitable for carrying fluids that are clean and free of suspended particles