

# VKRJV - DUAL BLOCK® regulating ball valve

DUAL BLOCK® regulating ball valve with female ends for solvent welding, JIS series

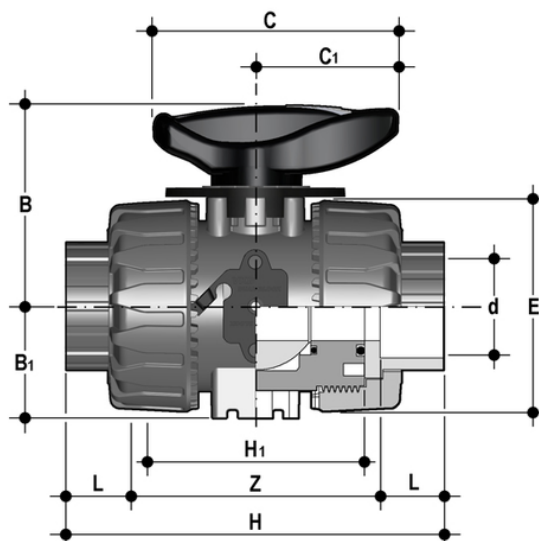

## EPDM

Objednací číslo	Materiál	Kategorie	Série	d	DN	PN	B	B (5:1)	C	C (5:1)	E	H	H (5:1)	L	Z	g
VKRJV012E	PVC-U system	Armatury	VKR DN 10÷50	1/2"	15	16	54	29	67	40	54	131	65	30	71	225
VKRJV034E	PVC-U system	Armatury	VKR DN 10÷50	3/4"	20	16	65	34,5	85	49	65	147	70	35	77	335
VKRJV100E	PVC-U system	Armatury	VKR DN 10÷50	1"	25	16	69,5	39	85	49	73	164	78	40	84	448
VKRJV114E	PVC-U system	Armatury	VKR DN 10÷50	1" 1/4	32	16	82,5	46	108	64	86	182	88	44	94	728
VKRJV112E	PVC-U system	Armatury	VKR DN 10÷50	1" 1/2	40	16	89	52	108	64	98	212	93	55	102	1015
VKRJV200E	PVC-U system	Armatury	VKR DN 10÷50	2"	50	16	108	62	134	76	122	248	111	63	122	1727

## FKM

Objednací číslo	Materiál	Kategorie	Série	d	DN	PN	B	B (5:1)	C	C (5:1)	E	H	H (5:1)	L	Z	g
VKRJV012F	PVC-U system	Armatury	VKR DN 10÷50	1/2"	15	16	54	29	67	40	54	131	65	30	71	225
VKRJV034F	PVC-U system	Armatury	VKR DN 10÷50	3/4"	20	16	65	34,5	85	49	65	147	70	35	77	335
VKRJV100F	PVC-U system	Armatury	VKR DN 10÷50	1"	25	16	69,5	39	85	49	73	164	78	40	84	448
VKRJV114F	PVC-U system	Armatury	VKR DN 10÷50	1" 1/4	32	16	82,5	46	108	64	86	182	88	44	94	728
VKRJV112F	PVC-U system	Armatury	VKR DN 10÷50	1" 1/2	40	16	89	52	108	64	98	212	93	55	102	1015
VKRJV200F	PVC-U system	Armatury	VKR DN 10÷50	2"	50	16	108	62	134	76	122	248	111	63	122	1727

# VKRJV – DUAL BLOCK® regulating ball valve

- HIPVC ergonomic multifunctional handle with **position indicator** and tool to adjust the ball seat carrier
- Flow direction and opening angle indication plate with **graduated scale with 5° detail** for clear and accurate readings
- 90° operating angle that permits **the use of standard** quarter turn **actuators**
- The patented ball design provides **linear flow adjustment** throughout its range of operation even when the valve is open just a few degrees and guarantees minimum pressure drops
- Patented **DUAL BLOCK®** system: prevents union nuts from loosening even under extreme operating conditions: e.g. vibration or thermal expansion
  
- Connection system for solvent weld, threaded and flanged joints
- Patented **SEAT STOP®** ball carrier system that lets you micro-adjust seals and minimise the axial force effect
- Easy radial dismounting allowing quick replacement of O-rings and ball seats without any need for tools
- **PN16 True Union valve body** made for rigid PVC-U injection moulding equipped with built-in bores for actuation. ISO 9393 compliant test requisites
- Option of dismounting downstream pipes with the valve in the closed position
- High surface finish stem with double O-Ring and double connection key to ball
- **Integrated bracket** for valve anchoring
- Ball seat carrier can be adjusted using the **Easytorque adjustment kit**
- Actuation option: version with electric modulating actuator with 4-20 mA / 0-10 V inlet and 4-20 mA / 0-10 V outlet to monitor the position
- Valve suitable for carrying fluids that are clean and free of suspended particles