

VKDLV - DUAL BLOCK® 2-way ball valve

DUAL BLOCK® 2-way ball valve with female ends for solvent welding, BS series

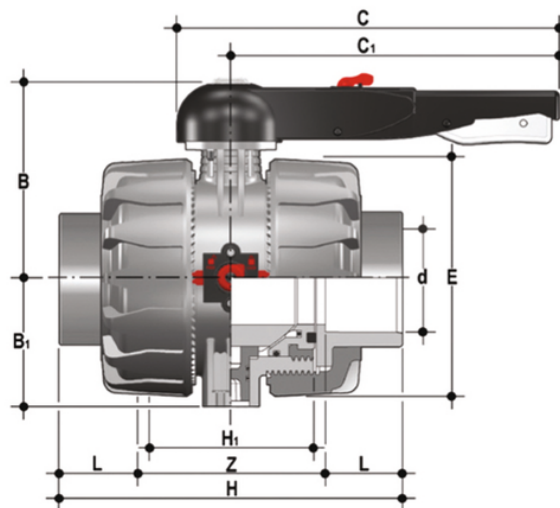

EPDM

Objednací číslo	Materiál	Kategorie	Série	d	DN	PN	B	B (5:1)	C	C (5:1)	E	H	H (5:1)	L	Z	g
VKDLV212E	PVC-U system	Armatury	VKD DN 65÷100	-	-	-	-	-	-	-	-	-	-	-	-	-
VKDLV300E	PVC-U system	Armatury	VKD DN 65÷100	3"	80	16	177	105	327	272	203	270	149	51	168	7250
VKDLV400E	PVC-U system	Armatury	VKD DN 65÷100	4"	100	16	195	129	385	330	238	308	167	63	182	10995

FKM

Objednací číslo	Materiál	Kategorie	Série	d	DN	PN	B	B (5:1)	C	C (5:1)	E	H	H (5:1)	L	Z	g
VKDLV300F	PVC-U system	Armatury	VKD DN 65÷100	3"	80	16	177	105	327	272	203	270	149	51	168	7250
VKDLV400F	PVC-U system	Armatury	VKD DN 65÷100	4"	100	16	195	129	385	330	238	308	167	63	182	10995
VKDLV212F	PVC-U system	Armatury	VKD DN 65÷100	-	-	-	-	-	-	-	-	-	-	-	-	-

VKDLV – DUAL BLOCK® 2-way ball valve

- HIPVC ergonomic multifunctional handle for quick operation, **lock and graduated adjustment in 10 positions**. Possibility of inhibiting rotation with a lock
- Customisable Labelling System: LCE module made of a transparent protection plug and **customisable tag holder** using the LSE set (available as accessory). The customisation lets you identify the valve on the system according to specific needs
- **DUAL BLOCK®** patented lock system that ensures union nut tightening hold even in severe conditions such as vibrations or heat dilation
- **Double stem** with double O-Rings for ball centring and operating torque reduction
- Machined high surface finish ball that guarantees a smooth operation and increased reliability

- Connection system for solvent weld, threaded and flanged joints
- Patented **SEAT STOP®** ball carrier system that lets you micro-adjust seals and minimise axial force effects
- Easy radial dismounting allowing quick replacement of O-rings and ball seats without any need for tools
- **PN16 True Union valve body** made for rigid PVC-U injection moulding equipped with built-in bores for actuation. ISO 9393 compliant test requisites
- Option of dismounting downstream pipes with the valve in the closed position
- **Full bore ball** with high surface finish
- **Integrated bracket** for valve anchoring
- Possibility of installing a manual reducer or pneumatic and/or electric actuators by applying an ISO standard bore PP-GR flange
- **STAINLESS steel co-moulded stem**, with square section as per ISO 5211
- Possibility to have handle with integrated LSQT limit micro switch, even as a retrofit in existing installations