

VEEAV - Easyfit 2-way ball valve

Easyfit 2-way ball valve with female ends, ASTM series

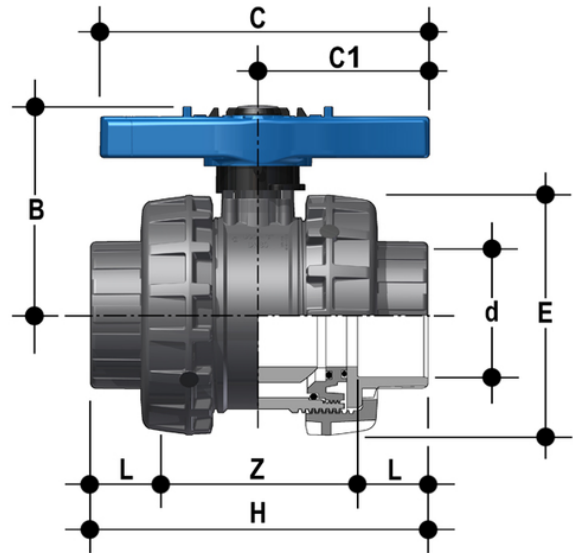

Objednáací číslo	Materiál	Kategorie	Série	d	DN	PN	B	C	C (5:1)	E	H	L	Z	g
VEEAV212E	PVC-U system	Armatury	VEE DN 65÷100	2"1/2	65	16	142	214	115	157	211	44,5	122	2750
VEEAV300E	PVC-U system	Armatury	VEE DN 65÷100	3"	80	16	151	239	126	174	248	48	152	3432
VEEAV400E	PVC-U system	Armatury	VEE DN 65÷100	4"	100	16	174,5	270	145	212	283	57,5	168	5814

VEEAV – Easyfit 2-way ball valve

- **Innovative quick release Easyfit handle** made up of a central hub firmly coupled with the stem by a **dual spoke grip** that can be released from the hub with a simple operation and used as a **ball seat adjustment tool**
- Settings for the customisable Labelling System using the LCE module (available as an accessory). The grey protection plug housed on the central hub can be replaced with the transparent plug and customisable tag holder with the LSE set (available as an accessory). The **customisation lets you identify the valve on the system** according to specific needs
- **PE seal system with locked carrier** adjustable via the Easyfit quick release handle
- **Stem** with high surface finish and **double O-Ring and PTFE anti-friction disk** that limits friction to a minimum and grants excellent operating torque
- Valve body set for SHE kit installation (available as an accessory) that blocks the closing and opening manoeuvres with a lock
- Machined high surface finish ball that guarantees a smooth operation and increased reliability

- **Patented Easyfit system:** innovative mechanism that lets you use the quick release handle to adjust the ball carrier
- Connection system for solvent weld and threaded joints
- **Valve material compatibility** (PVC-U) with water, drinking ware and other food substances according to **current regulations**
- Easy radial dismounting allowing quick replacement of O-rings and ball seats without any need for tools
- **PN16 True Union valve body** made for PVC-U injection moulding and European Directive 2014/68/EU (PED) compliant for pressurised equipment. ISO 9393 compliant test requirements
- Valve body with built-in anchoring frame for the special **Power Quick Easyfit module** dedicated to the installation of pneumatic and electric actuators or accessories
- Option of dismounting downstream pipes with the valve in the closed position
- Floating **full bore ball** with high surface finish made in CNC work stations to achieve precise dimensional tolerance and high surface finish