

VKDOC – DUAL BLOCK® 2-WAY BALL VALVE

DUAL BLOCK® 2-way ball valve with fixed flanges, drilled EN/ISO/DIN PN10/16. Face to face according to EN 558-1

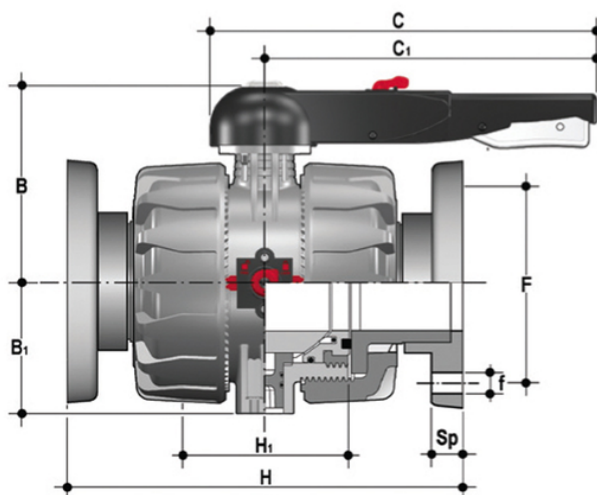

EPDM

| Objednací číslo | Materiál | Kategorie | Série | d | DN | PN | B | B (5:1) | C | C (5:1) | product.detail.attribute.F | product.detail.attribute.f | H | H (5:1) | product |
|-----------------|--------------|-----------|---------------|-----|-----|----|-----|---------|-----|---------|----------------------------|----------------------------|-----|---------|---------|
| VKDOC075E | PVC-C system | Armatury | VKD DN 65÷100 | 75 | 65 | 16 | 164 | 87 | 327 | 175 | 145 | 17 | 290 | 133 | 21 |
| VKDOC090E | PVC-C system | Armatury | VKD DN 65÷100 | 90 | 80 | 16 | 177 | 105 | 327 | 272 | 160 | 17 | 310 | 149 | 21,5 |
| VKDOC110E | PVC-C system | Armatury | VKD DN 65÷100 | 110 | 100 | 16 | 195 | 129 | 385 | 330 | 180 | 17 | 350 | 167 | 21,5 |

FKM

| Objednací číslo | Materiál | Kategorie | Série | d | DN | PN | B | B (5:1) | C | C (5:1) | product.detail.attribute.F | product.detail.attribute.f | H | H (5:1) | product |
|-----------------|--------------|-----------|---------------|-----|-----|----|-----|---------|-----|---------|----------------------------|----------------------------|-----|---------|---------|
| VKDOC075F | PVC-C system | Armatury | VKD DN 65÷100 | 75 | 65 | 16 | 164 | 87 | 327 | 175 | 145 | 17 | 290 | 133 | 21 |
| VKDOC090F | PVC-C system | Armatury | VKD DN 65÷100 | 90 | 80 | 16 | 177 | 105 | 327 | 272 | 160 | 17 | 310 | 149 | 21,5 |
| VKDOC110F | PVC-C system | Armatury | VKD DN 65÷100 | 110 | 100 | 16 | 195 | 129 | 385 | 330 | 180 | 17 | 350 | 167 | 21,5 |

VKDOC – DUAL BLOCK® 2-WAY BALL VALVE

- HIPVC ergonomic multifunctional handle for quick operation, **lock and graduated adjustment in 10 positions**. Possibility of inhibiting rotation with a lock
- Customisable Labelling System: LCE module made of a transparent protection plug and **customisable tag holder** using the LSE set (available as accessory). The customisation lets you identify the valve on the system according to specific needs
- **DUAL BLOCK®** patented lock system that ensures union nut tightening hold even in severe conditions such as vibrations or heat dilation
- **Double stem** with double O-Rings for ball centring and operating torque reduction
- Machined high surface finish ball that guarantees a smooth operation and increased reliability

- Connection system for solvent weld, threaded and flanged joints
- Patented **SEAT STOP®** ball carrier system that lets you micro-adjust seals and minimise axial force effects
- Easy radial dismounting allowing quick replacement of O-rings and ball seats without any need for tools
- **PN16 True Union valve body** made for rigid PVC-U injection moulding equipped with built-in bores for actuation. ISO 9393 compliant test requisites
- Option of dismounting downstream pipes with the valve in the closed position
- **Full bore ball** with high surface finish
- **Integrated bracket** for valve anchoring
- Possibility of installing a manual reducer or pneumatic and/or electric actuators by applying an ISO standard bore PP-GR flange
- **STAINLESS steel co-moulded stem**, with square section as per ISO 5211
- Possibility to have handle with integrated LSQT limit micro switch, even as a retrofit in existing installations