

# SVUFV - RELIEF VALVE

Relief valve with unionised BS parallel socket threaded ends

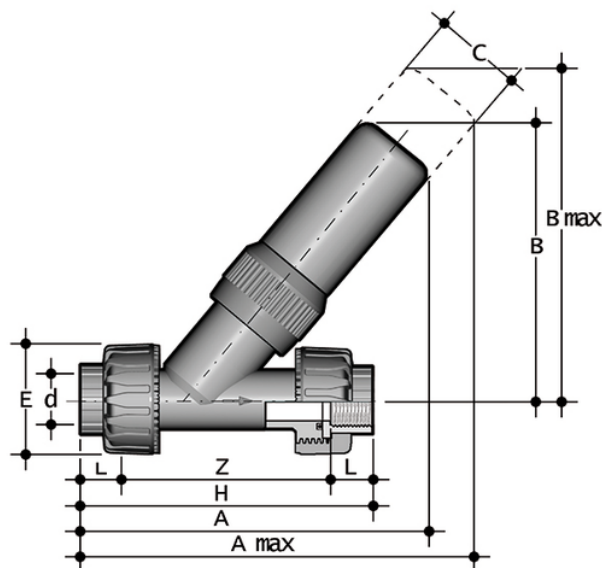

## EPDM

Objednačí číslo	Materiál	Kategorie	Série	product.detail.attribute.R	DN	product.detail.attribute.A	product.detail.attribute.A max	B	product.detail.attribute.B max
SVUFV012E	PVC-U system	Armatury	SV DN 15÷25	1/2"	15	153	193	118	170
SVUFV034E	PVC-U system	Armatury	SV DN 15÷25	3/4"	20	191	271	150	220
SVUFV100E	PVC-U system	Armatury	SV DN 15÷25	1"	25	226	296	175	230

## FKM

Objednačí číslo	Materiál	Kategorie	Série	product.detail.attribute.R	DN	product.detail.attribute.A	product.detail.attribute.A max	B	product.detail.attribute.B max
SVUFV012F	PVC-U system	Armatury	SV DN 15÷25	1/2"	15	153	193	118	170
SVUFV034F	PVC-U system	Armatury	SV DN 15÷25	3/4"	20	191	271	150	220
SVUFV100F	PVC-U system	Armatury	SV DN 15÷25	1"	25	226	296	175	230

# SVUFV – RELIEF VALVE

- Ergonomic HIPVC handle equipped with **removable tool to adjust the ball seat carrier**.
- **Handle lock 0°– 90°** SHKD (available as an accessory) ergonomically operable during service and padlockable
- Robust **integrated bracket for valve anchoring**, for easy and quick automation even after valve installation on the system via the Power Quick module (optional)
- **DUAL BLOCK®** patented lock system that ensures union nut tightening hold even in severe conditions such as vibrations or heat dilation
- Machined high surface finish ball that guarantees a smooth operation and increased reliability
  
- Connection system for solvent weld, threaded and flanged joints
- Patented **SEAT STOP®** ball carrier system that lets you micro-adjust ball seats and minimise the axial force effect
- Easy radial dismounting allowing quick replacement of O-rings and ball seats without any need for tools
- **PN16 True Union valve body** made for rigid PVC-U injection moulding equipped with built-in bores for actuation. ISO 9393 compliant test requisites
- Option of dismounting downstream pipes with the valve in the closed position
- Floating **full bore ball** with high surface finish
- **Integrated bracket** for valve anchoring
- Ball seat carriers can be adjusted using the **Easytorque adjustment kit**
- Possibility to have handle with integrated LSQT limit micro switch, even as a retrofit in existing installations