

DKDM - DIALOCK® 2-way diaphragm valve

DIALOCK® diaphragm valve with male ends for socket welding, metric series

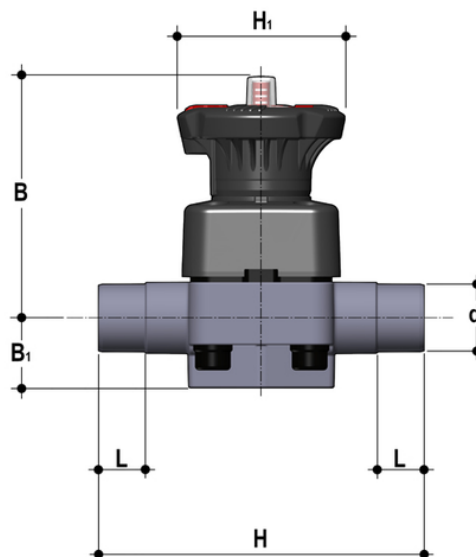

EPDM

Objednací číslo	Materiál	Kategorie	Série	d	DN	PN	B	B (5:1)	H	H (5:1)	L	g
DKDM020E	PP-H system	Armatury	DK DN 15÷65	20	15	10	102	25	124	80	16	430
DKDM025E	PP-H system	Armatury	DK DN 15÷65	25	20	10	105	30	144	80	19	445
DKDM032E	PP-H system	Armatury	DK DN 15÷65	32	25	10	114	33	154	80	22	620
DKDM040E	PP-H system	Armatury	DK DN 15÷65	40	32	10	119	30	174	80	26	650
DKDM050E	PP-H system	Armatury	DK DN 15÷65	50	40	10	149	35	194	120	31	1380
DKDM063E	PP-H system	Armatury	DK DN 15÷65	63	50	10	172	46	224	120	38	2136
DKDM075E	PP-H system	Armatury	DK DN 15÷65	75	65	10	172	46	284	120	44	2225

EPDM

Objednací číslo	Materiál	Kategorie	Série	d	DN	PN	B	B (5:1)	H	H (5:1)	L	g
DKDM020E0SF	PP-H system	Armatury	DK DN 15÷65	20	15	10	102	25	124	80	16	430
DKDM025E0SF	PP-H system	Armatury	DK DN 15÷65	25	20	10	105	30	144	80	19	445
DKDM032E0SF	PP-H system	Armatury	DK DN 15÷65	32	25	10	114	33	154	80	22	620
DKDM040E0SF	PP-H system	Armatury	DK DN 15÷65	40	32	10	119	30	174	80	26	650
DKDM050E0SF	PP-H system	Armatury	DK DN 15÷65	50	40	10	149	35	194	120	31	1380
DKDM063E0SF	PP-H system	Armatury	DK DN 15÷65	63	50	10	172	46	224	120	38	2136
DKDM075E0SF	PP-H system	Armatury	DK DN 15÷65	75	65	10	172	46	284	120	44	2225

DKDM - DIALOCK® 2-way diaphragm valve

FKM

Objednací číslo	Materiál	Kategorie	Série	d	DN	PN	B	B (5:1)	H	H (5:1)	L	g
DKDM020F	PP-H system	Armatury	DK DN 15÷65	20	15	10	102	25	124	80	16	430
DKDM025F	PP-H system	Armatury	DK DN 15÷65	25	20	10	105	30	144	80	19	445
DKDM032F	PP-H system	Armatury	DK DN 15÷65	32	25	10	114	33	154	80	22	620
DKDM040F	PP-H system	Armatury	DK DN 15÷65	40	32	10	119	30	174	80	26	650
DKDM050F	PP-H system	Armatury	DK DN 15÷65	50	40	10	149	35	194	120	31	1380
DKDM063F	PP-H system	Armatury	DK DN 15÷65	63	50	10	172	46	224	120	38	2136
DKDM075F	PP-H system	Armatury	DK DN 15÷65	75	65	10	172	46	284	120	44	2225

PTFE

Objednací číslo	Materiál	Kategorie	Série	d	DN	PN	B	B (5:1)	H	H (5:1)	L	g
DKDM020P	PP-H system	Armatury	DK DN 15÷65	20	15	10	102	25	124	80	16	430
DKDM025P	PP-H system	Armatury	DK DN 15÷65	25	20	10	105	30	144	80	19	445
DKDM032P	PP-H system	Armatury	DK DN 15÷65	32	25	10	114	33	154	80	22	620
DKDM040P	PP-H system	Armatury	DK DN 15÷65	40	32	10	119	30	174	80	26	650
DKDM050P	PP-H system	Armatury	DK DN 15÷65	50	40	10	149	35	194	120	31	1380
DKDM063P	PP-H system	Armatury	DK DN 15÷65	63	50	10	172	46	224	120	38	2136
DKDM075P	PP-H system	Armatury	DK DN 15÷65	75	65	10	172	46	284	120	44	2225

PTFE

Objednací číslo	Materiál	Kategorie	Série	d	DN	PN	B	B (5:1)	H	H (5:1)	L	g
DKDM020POSF	PP-H system	Armatury	DK DN 15÷65	20	15	10	102	25	124	80	16	430
DKDM025POSF	PP-H system	Armatury	DK DN 15÷65	25	20	10	105	30	144	80	19	445
DKDM032POSF	PP-H system	Armatury	DK DN 15÷65	32	25	10	114	33	154	80	22	620
DKDM040POSF	PP-H system	Armatury	DK DN 15÷65	40	32	10	119	30	174	80	26	650
DKDM050POSF	PP-H system	Armatury	DK DN 15÷65	50	40	10	149	35	194	120	31	1380
DKDM063POSF	PP-H system	Armatury	DK DN 15÷65	63	50	10	172	46	224	120	38	2136
DKDM075POSF	PP-H system	Armatury	DK DN 15÷65	75	65	10	172	46	284	120	44	2225

DKDM - DIALOCK® 2-way diaphragm valve

- **High visibility graduated optical position indicator** protected by a transparent cap with seal O-Ring
- **Customisation plate:** the customisation lets you identify the valve on the system according to specific needs
- **DIALOCK® SYSTEM:** innovative handwheel with a patented immediate and ergonomic operating locking device that allows it **to be adjusted and locked in over 300 positions**
- **Handwheel and bonnet in** high mechanical strength and chemically resistant **PP-GR**, providing full protection by isolating all internal metal parts from contact with external agents
- **Floating pin connection** between the control screw and diaphragm to prevent concentrated loads, improve the seal and extend its lifetime
- **New design of valve body interior: substantially increased flow coefficient** and reduced pressure drop. The degree of efficiency reached has also **enabled the size and weight of the valve to be reduced**
- **Adjustment linearity:** the internal profiles of the valve also greatly improve its characteristic curve, resulting in **extremely sensitive and precise adjustment** along the entire stroke of the shutter
- **Valve anchoring** bracket **integrated in the body**, with threaded metal inserts allowing **simple panel or wall mounting** using the PMDK mounting plate (supplied as an accessory)

- Connection system for solvent weld, threaded and flanged joints
- **Optimised fluid dynamic design:** maximum output flow rate thanks to the optimised efficiency of the fluid dynamics that characterise the new internal geometry of the body
- **Internal components in metal, totally isolated from the fluid** and external environment
- **Modularity of the range:** only 2 handwheel and 4 diaphragm and bonnet sizes for 7 different valve sizes
- Non-rising handwheel that stays at the same height during rotation, equipped with a graduated optical indicator protected by a transparent PVC cap with seal O-Ring
- Bonnet fastening screws in stainless steel protected against the external environment by PE plugs. Absence of metal parts exposed to the external environment to prevent any risk of corrosion.
- **CDSA** (Circular Diaphragm Sealing Angle) system that, thanks to the uniform distribution of shutter pressure on the diaphragm seal, offers the following advantages:
 - reduction in the tightening torque of the screws fixing the actuator to the valve body
 - reduced mechanical stress on all valve components (actuator, body and diaphragm)
 - easy to clean valve interior
 - low risk of the accumulation of deposits, contamination or damage to the diaphragm due to crystallisation
 - operating torque reduction