

SXEAV - Easyfit True Union ball and spring check valve

Easyfit ball check valve with female ends for solvent welding, ASTM series

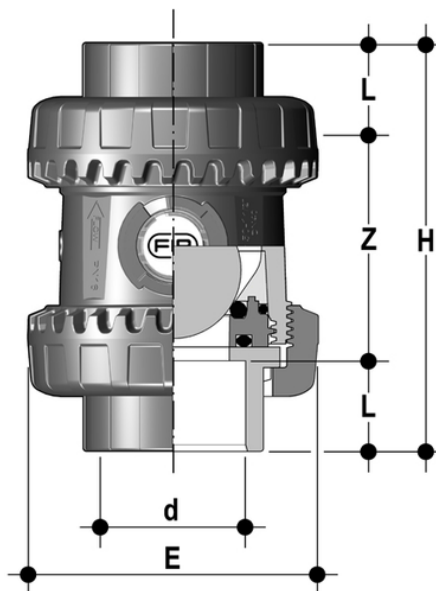

EPDM

Objednací číslo	Materiál	Kategorie	Série	d	DN	PN	E	H	L	Z	g
SXEAV012E	PVC-U system	Armatury	SXE-SSE DN 10÷50	1/2"	15	16	54	96	22,5	51	148
SXEAV034E	PVC-U system	Armatury	SXE-SSE DN 10÷50	3/4"	20	16	63	105	25,5	54	190
SXEAV100E	PVC-U system	Armatury	SXE-SSE DN 10÷50	1"	25	16	72	117	28,7	59,5	300
SXEAV114E	PVC-U system	Armatury	SXE-SSE DN 10÷50	1 1/4"	32	16	85	136	32	72	460
SXEAV112E	PVC-U system	Armatury	SXE-SSE DN 10÷50	1 1/2"	40	16	100	147	35	77	675
SXEAV200E	PVC-U system	Armatury	SXE-SSE DN 10÷50	2"	50	16	118	174	38,2	97,6	1080

FKM

Objednací číslo	Materiál	Kategorie	Série	d	DN	PN	E	H	L	Z	g
SXEAV012F	PVC-U system	Armatury	SXE-SSE DN 10÷50	1/2"	15	16	54	96	22,5	51	148
SXEAV034F	PVC-U system	Armatury	SXE-SSE DN 10÷50	3/4"	20	16	63	105	25,5	54	190
SXEAV100F	PVC-U system	Armatury	SXE-SSE DN 10÷50	1"	25	16	72	117	28,7	59,5	300
SXEAV114F	PVC-U system	Armatury	SXE-SSE DN 10÷50	1 1/4"	32	16	85	136	32	72	460
SXEAV112F	PVC-U system	Armatury	SXE-SSE DN 10÷50	1 1/2"	40	16	100	147	35	77	675
SXEAV200F	PVC-U system	Armatury	SXE-SSE DN 10÷50	2"	50	16	118	174	38,2	97,6	1080

SXEAV – Easyfit True Union ball and spring check valve

- **Customisable Labelling System: built-in LCE module** on the valve body made up of transparent protection plug and customisable tag holder using the LSE set (available as accessory). The customisation potential lets you identify the valve on the system according to specific needs.
- **Optimised dynamic fluid design:** energy savings thanks to the improved valve Kv value with consequent pressure drop reduction
- High surface finish ball shutter: **wear reduction**, increase in working life and reduced valve maintenance. Ideal for conveying dirty fluids, even with suspended solids and filaments thanks to the special design that permits **internal valve selfcleaning**
- **Locked ball seat carrier:** safe dismounting for maintenance with the Easyfit multifunctional handle or Easytorque kit
- Ideal for horizontal installations: **perfect seal even with low back pressure. Silent** and durable even with strong vibrations and pulsating fluid
- PVC-U shutter and springs available made of STAINLESS steel 316, Hastelloy C276, A316 PTFE encapsulated: maximum reliability in a **wide field of applications** from salt water to aggressive acids

- Connection system for solvent weld and threaded joints
- **Valve material compatibility (PVC-U)** with water conveyance, drinking water and other food substances according to current regulations
- **PN16 True Union** valve body made for PVC-U injection moulding and European Directive 2014/68/EU (PED) compliant for pressurised equipment. ISO 9393 compliant test requirements
- **Short face to face dimension** according to international regulation ISO 7508 series III and European regulation EN 1452 "short" and fully interchangeable with VXE and VEE DN 10÷50 ball valve models
- Union nuts with rack for tightening adjustment via Easyfit handle or via Easytorque adjustment kit (available as accessories)
- **Vertical** (preferable for SXE model) and **horizontal installation** potential