

DKLUIC - DIALOCK® 2-WAY DIAPHRAGM VALVE

DIALOCK® diaphragm valve with stroke limiter and female union ends for solvent welding, metric series

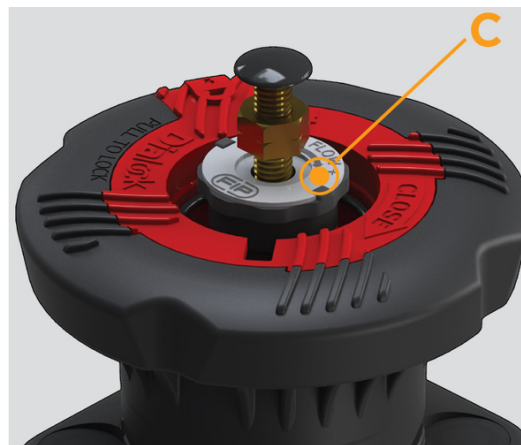
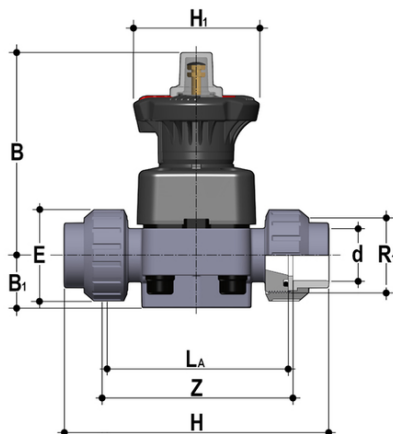

EPDM

Objednací číslo	Materiál	Kategorie	Série	d	DN	PN	B	B (5:1)	E	H	H (5:1)	La	product.detail.attribute.R[5:1]	Z	g
DKLUIC020E	PVC-C system	Armatury	DK DN 15÷65	20	15	10	115	25	41	129	80	90	1"	100	539
DKLUIC025E	PVC-C system	Armatury	DK DN 15÷65	25	20	10	118	30	50	154	80	108	1 1/4"	116	606
DKLUIC032E	PVC-C system	Armatury	DK DN 15÷65	32	25	10	127	33	58	168	80	116	1 1/2"	124	842
DKLUIC040E	PVC-C system	Armatury	DK DN 15÷65	40	32	10	132	30	72	192	80	134	2"	140	975
DKLUIC050E	PVC-C system	Armatury	DK DN 15÷65	50	40	10	175	35	79	222	120	154	2 1/4"	160	1874
DKLUIC063E	PVC-C system	Armatury	DK DN 15÷65	63	50	10	200	46	98	266	120	184	2 3/4"	190	2812

FKM

Objednací číslo	Materiál	Kategorie	Série	d	DN	PN	B	B (5:1)	E	H	H (5:1)	La	product.detail.attribute.R[5:1]	Z	g
DKLUIC020F	PVC-C system	Armatury	DK DN 15÷65	20	15	10	115	25	41	129	80	90	1"	100	539
DKLUIC025F	PVC-C system	Armatury	DK DN 15÷65	25	20	10	118	30	50	154	80	108	1 1/4"	116	606
DKLUIC032F	PVC-C system	Armatury	DK DN 15÷65	32	25	10	127	33	58	168	80	116	1 1/2"	124	842
DKLUIC040F	PVC-C system	Armatury	DK DN 15÷65	40	32	10	132	30	72	192	80	134	2"	140	975

DKLUIC - DIALOCK® 2-WAY DIAPHRAGM VALVE

Objednací číslo	Materiál	Kategorie	Série	d	DN	PN	B	B (5:1)	E	H	H (5:1)	La	product.detail.attribute.R[5:1]	Z	g
DKLUIC050F	PVC-C system	Armatury	DK DN 15÷65	50	40	10	175	35	79	222	120	154	2"1/4	160	1874
DKLUIC063F	PVC-C system	Armatury	DK DN 15÷65	63	50	10	200	46	98	266	120	184	2"3/4	190	2812

PTFE

Objednací číslo	Materiál	Kategorie	Série	d	DN	PN	B	B (5:1)	E	H	H (5:1)	La	product.detail.attribute.R[5:1]	Z	g
DKLUIC025P	PVC-C system	Armatury	DK DN 15÷65	25	20	10	118	30	50	154	80	108	1"1/4	116	606
DKLUIC032P	PVC-C system	Armatury	DK DN 15÷65	32	25	10	127	33	58	168	80	116	1"1/2	124	842
DKLUIC040P	PVC-C system	Armatury	DK DN 15÷65	40	32	10	132	30	72	192	80	134	2"	140	975
DKLUIC050P	PVC-C system	Armatury	DK DN 15÷65	50	40	10	175	35	79	222	120	154	2"1/4	160	1874
DKLUIC063P	PVC-C system	Armatury	DK DN 15÷65	63	50	10	200	46	98	266	120	184	2"3/4	190	2812
DKLUIC020P	PVC-C system	Armatury	DK DN 15÷65	20	15	10	115	25	41	129	80	90	1"	100	539

DKLUIC - DIALOCK® 2-WAY DIAPHRAGM VALVE

- **High visibility graduated optical position indicator** protected by a transparent cap with seal O-Ring
- **Customisation plate:** the customisation lets you identify the valve on the system according to specific needs
- **DIALOCK® SYSTEM:** innovative handwheel with a patented immediate and ergonomic operating locking device that allows it **to be adjusted and locked in over 300 positions**
- **Handwheel and bonnet in** high mechanical strength and chemically resistant **PP-GR**, providing full protection by isolating all internal metal parts from contact with external agents
- **Floating pin connection** between the control screw and diaphragm to prevent concentrated loads, improve the seal and extend its lifetime
- **New design of valve body interior: substantially increased flow coefficient** and reduced pressure drop. The degree of efficiency reached has also **enabled the size and weight of the valve to be reduced**
- **Adjustment linearity:** the internal profiles of the valve also greatly improve its characteristic curve, resulting in **extremely sensitive and precise adjustment** along the entire stroke of the shutter
- **Valve anchoring** bracket **integrated in the body**, with threaded metal inserts allowing **simple panel or wall mounting** using the PMDK mounting plate (supplied as an accessory)

- Connection system for solvent weld, threaded and flanged joints
- **Optimised fluid dynamic design:** maximum output flow rate thanks to the optimised efficiency of the fluid dynamics that characterise the new internal geometry of the body
- **Internal components in metal, totally isolated from the fluid** and external environment
- **Modularity of the range:** only 2 handwheel and 4 diaphragm and bonnet sizes for 7 different valve sizes
- Non-rising handwheel that stays at the same height during rotation, equipped with a graduated optical indicator protected by a transparent PVC cap with seal O-Ring
- Bonnet fastening screws in stainless steel protected against the external environment by PE plugs. Absence of metal parts exposed to the external environment to prevent any risk of corrosion.
- **CDSA** (Circular Diaphragm Sealing Angle) system that, thanks to the uniform distribution of shutter pressure on the diaphragm seal, offers the following advantages:
 - reduction in the tightening torque of the screws fixing the actuator to the valve body
 - reduced mechanical stress on all valve components (actuator, body and diaphragm)
 - easy to clean valve interior
 - low risk of the accumulation of deposits, contamination or damage to the diaphragm due to crystallisation
 - operating torque reduction