

VRIV - Check valve

Check valve with female ends for solvent welding, metric series

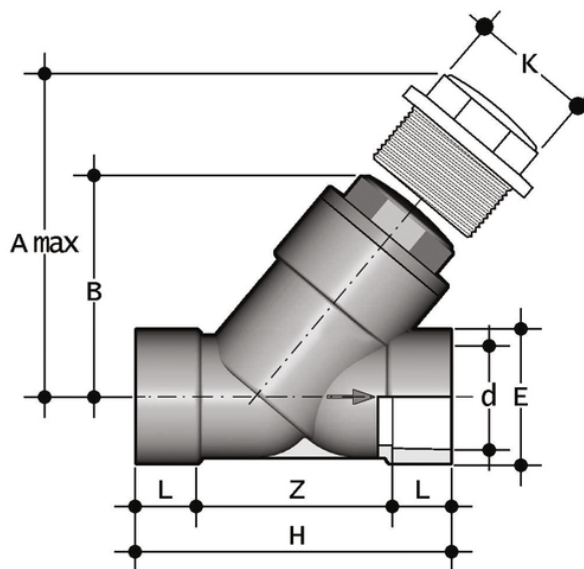

Objednáací číslo	Materiál	Kategorie	Série	d	DN	PN	product.detail.attribute.A max	B	E	H	product.detail.attribute.K	L	Z	produ
VRIV075E	PVC-U system	Armatury	VR DN 10÷100	75	65	10	300	179	104	243	96	44	155	B
VRIV090E	PVC-U system	Armatury	VR DN 10÷100	90	80	6	325	192	116	262	105	51	160	B
VRIV110E	PVC-U system	Armatury	VR DN 10÷100	110	100	6	385	231	138	325	-	61	203	C

VRIV - Check valve

- Connection system for solvent weld, threaded and flanged joints
- **No metal parts in contact with the fluid**
- **Piston with counterweight** able to work with high intensity fluid
- Limited pressure drop. Only minimum back pressure is required for the hermetic seal
- **Valve material compatibility** (PVC-U) with water conveyance, drinking water and other food substances according to **current regulations**
- Can be maintained with the valve body installed