

VMOV/CP NC - PNEUMATICALLY ACTUATED DIAPHRAGM VALVE DN 80:100

Pneumatically actuated diaphragm valve with PN10/16 flanged monolithic body. Face to face according to EN 558-1, Normally closed.

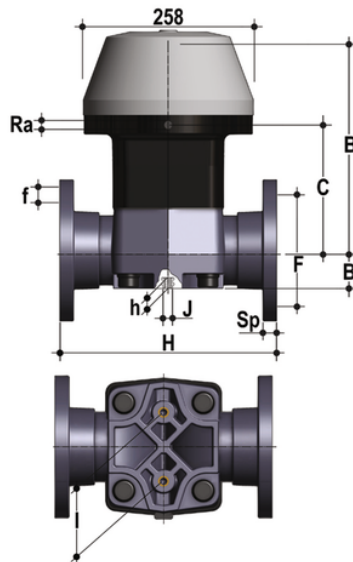

EPDM

Objednací číslo	Materiál	Kategorie	Série	d	DN	PN	B	product.detail.attribute.B1	C	H	product.detail.attribute.h	product.d
VMOVNC090E	FLS Measurement Instrumentation	Pneumaticky ovládané pohonované armatury	VM/CP DN 80÷100	90	80	6	317	64	179	310	23	1/4"
VMOVNC110E	FLS Measurement Instrumentation	Pneumaticky ovládané pohonované armatury	VM/CP DN 80÷100	110	100	6	347	72	260	350	23	1/4"

FKM

Objednací číslo	Materiál	Kategorie	Série	d	DN	PN	B	product.detail.attribute.B1	C	H	product.detail.attribute.h	product.d
VMOVNC090F	FLS Measurement Instrumentation	Pneumaticky ovládané pohonované armatury	VM/CP DN 80÷100	90	80	6	317	64	179	310	23	1/4"
VMOVNC110F	FLS Measurement Instrumentation	Pneumaticky ovládané pohonované armatury	VM/CP DN 80÷100	110	100	6	347	72	260	350	23	1/4"

VMOV/CP NC - PNEUMATICALLY ACTUATED DIAPHRAGM VALVE DN 80:100

PTFE

Objednáací číslo	Materiál	Kategorie	Série	d	DN	PN	B	product.detail.attribute.B1	C	H	product.detail.attribute.h	product.
VMOVNC090P	FLS Measurement Instrumentation	Pneumaticky ovládané pohonované armatury	VM/CP DN 80÷100	90	80	6	317	64	179	310	23	1/4"
VMOVNC110P	FLS Measurement Instrumentation	Pneumaticky ovládané pohonované armatury	VM/CP DN 80÷100	110	100	6	347	72	260	350	23	1/4"

VMOV/CP NC – PNEUMATICALLY ACTUATED DIAPHRAGM VALVE DN 80:100

The PP-GR diaphragm actuator is characterised by significant construction strength and makes VM the ideal choice for heavy-duty and chemically aggressive applications.

- PP-GR diaphragm actuator marked by high construction strength. The upper part is reinforced in steel in the Normally closed configuration. The absence of metal parts exposed to the external environment prevents any risk of corrosion.
- The special control diaphragm reinforced with textile fibres allows for up to 10 million operating cycles without showing any signs of wear.
- High resistance stainless steel stem with floating pin connection between the actuator stem and diaphragm to prevent concentrated loads, improve the seal and extend its lifetime.
- New valve body internal design. Substantially higher flow coefficient and lower pressure drops. Improved adjustment curve for efficient and precise flow regulation.
- Connection system using solvent welded and flanged joints
- Optimised fluid dynamic design: maximum output flow rate thanks to the optimised efficiency of the fluid dynamics that characterise the new internal geometry of the body
- Robust and reliable PP-GR diaphragm actuator suited to be used in severe environmental and chemically aggressive conditions
- Bonnet fastening screws in STAINLESS steel protected against the external environment by PE plugs
- New flanged bodies: the new bodies, characterised by a monolithic flanged structure, are available in PVC-U, PVC-C, PP-H and PVDF. This design, free of joints between the body and flanges, greatly reduces mechanical stress and increases system performance