

DKDUIV/CP NO - DIRECT ACTION PNEUMATICALLY ACTUATED DIAPHRAGM VALVE DN 15:65

Pneumatically actuated diaphragm valve with female union ends for solvent welding, metric series, Normally Open, Direct Acting.

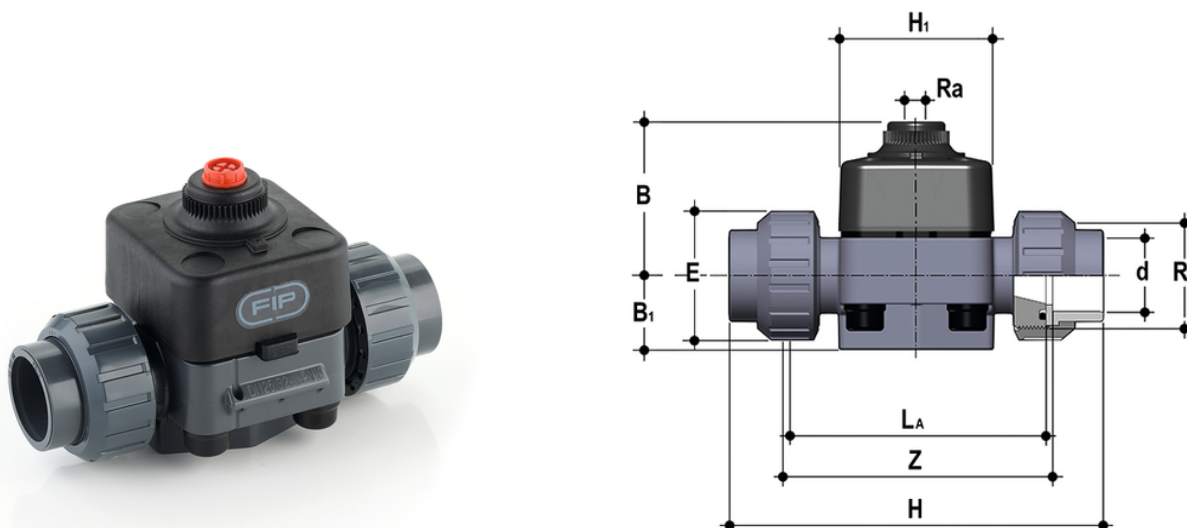

Objednací číslo	Materiál	Kategorie	Série	d	DN	PN	B	B (5:1)	E	H	product.detail.attribute.h	H (5:1)	La	product deta
DKDUIVNO020E	FLS Measurement Instrumentation	Pneumaticky ovládané pohonované armatury	DKD/ CP DN 15÷65	20	15	8	58	25	41	129	12	65	90	1"
DKDUIVNO025E	FLS Measurement Instrumentation	Pneumaticky ovládané pohonované armatury	DKD/ CP DN 15÷65	25	20	8	61	29,5	50	154	12	65	108	1"1/4
DKDUIVNO032E	FLS Measurement Instrumentation	Pneumaticky ovládané pohonované armatury	DKD/ CP DN 15÷65	32	25	8	70	33	58	168	12	70	116	1"1/2
DKDUIVNO040E	FLS Measurement Instrumentation	Pneumaticky ovládané pohonované armatury	DKD/ CP DN 15÷65	40	32	8	72	30	72	192	12	70	134	2"
DKDUIVNO050E	FLS Measurement Instrumentation	Pneumaticky ovládané pohonované armatury	DKD/ CP DN 15÷65	50	40	8	87	35	79	222	16	99	154	2"1/4
DKDUIVNO063E	FLS Measurement Instrumentation	Pneumaticky ovládané pohonované armatury	DKD/ CP DN 15÷65	63	50	8	109	46	98	266	16	114	184	2"3/4

DKDUIV/CP NO – DIRECT ACTION PNEUMATICALLY ACTUATED DIAPHRAGM VALVE DN 15:65

The valve comprises three elements: body, diaphragm and sealing bonnet. Due to the action of the compressed air in the bonnet, the diaphragm is pressed against the body saddle interrupting the flow. This simplified operating principle and the lower number of components guarantees high reliability and durability.

- PP-GR sealing bonnet marked by high construction strength. The absence of metal parts exposed to the external environment prevents any risk of corrosion.
- The special sealing diaphragm reinforced with textile fibres allows longer operation to be reached without showing any signs of wear.
- New valve body internal design. Substantially higher flow coefficient and lower pressure drops. The degree of efficiency reached has also enabled the size and weight of the valve to be reduced.
- Connection system using solvent welded and threaded joints
- Optimised fluid dynamic design: maximum output flow rate thanks to the optimised efficiency of the fluid dynamics that characterise the new internal geometry of the body
- In the Standard version, equipped with textile fibre reinforced diaphragm
- Bonnet fastening screws in STAINLESS steel protected against the external environment by PE plugs
- Easy to clean valve interior
- Low risk of the accumulation of deposits, contamination or damage to the diaphragm due to crystallisation
- Easy to replace diaphragm seal.